

Quantometer QA / QAe

Flow meters
with mechanical (QA) or
electronic index (QAe)



Applications

Media: Methane, town gas, natural gas,*
Branches: Industry, trade, chemicals, food-stuffs,**
Functions: Metering, control, regulation, registration,***

Brief information

Elster-Instromet quantometers are highly reliable gas meters which can be used throughout the entire field of flow metering and which fulfil all of the varying requirements of industrial metering. The QA and QAe quantometers work on the principle of the rotating turbine wheel. The rotation of the turbine wheel is proportional to the volume of the flowing gas and this volume (V_b/m^3) is registered by either a mechanical (QA) or an electronic (QAe) index.

Self-lubricating bearings ensure that the quantometers operate completely without any maintenance.

On account of the proven metering principle and the quality of the materials in use, the quantometers meet the highest standards. By using the quantometers in production and heating processes, it is possible to control the flow of gas precisely and therefore optimise the use of energy.

The QA quantometers are fitted with a 7-digit mechanical index which registers the volume V_b in cubic meters (m^3).

The QAe quantometers are equipped with an electronic index. Besides the normal registration of the total volume (V_b, m^3), the QAe can also display the flow rate ($Q_b, m^3/h$), the volume of a key-day (m^3 / V_b on the key-day) and the date of the key-day. This means that the user can easily calculate the gas consumption for any specific part of the building or for any cost centre at any chosen time.

Installation tips: The Elster-Instromet quantometers can be installed easily in the pipeline. The position of the installation can be selected as required. The flow direction is clearly marked by an arrow on the meter housing.

Interfaces/Outputs:

- QA: E1 Reed switch
- QA/QAe: E 200 Namur output
(in accordance with DIN EN 50227)
- QAe: Optical interface
(in accordance with EN 1434 – ZVEI- kompatibel)
- QAe: M-BUS interface
(in accordance with EN 14349)

Main features

- Compact gas meter
- Meter sizes QA/e 10 - QA/e 1000
- Flow ranges 1.6 –1600 m^3/h
- Measuring range up to 1:20, at higher pressures up to 1:50
- Nominal width DN 25 - DN 150
- Aluminium housing
- Gas temperature -10 °C up to +60 °C
- Ambient temperature
QA: -20 °C up to +70 °C
QAe: 0 °C up to +50 °C
- Maintenance-free
- QA: protection class IP52
7-digit mechanical index
- QAe: protection class IP44
7-digit LCD display showing:
 - actual volume (basic state)
 - high-resolution volume (digits after the point)
 - current flow rate
 - key-day values / key-day date
 - back-flow volume
- Metering accuracy in wide ranges independent of physical characteristics of the gas such as density, temperature and pressure
- DVGW approved

* non-aggressive gases, inert gases

** district heating, power plants, petrochemicals, station building

*** monitoring, evaluation

Quantometer QA / QAe: Flow meters with mechanical (QA) or electronic index (QAe)

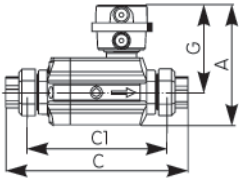
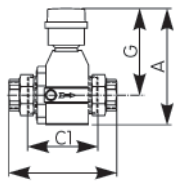
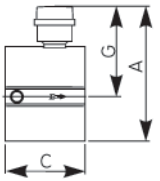
Technical data		QA/e 10 - QA/e 40 G I	QA/e 40 GF I	QA/e 65 - QA/e 1000 Z I				
								
Medium/ maximum pressure	Combustible gases	4 bar	4 bar	20 bar (QAe 4 bar)				
	Air, non-aggressive gases, inert gases	16 bar	16 bar	20 bar				
Metering technology	Measuring range m³/h	QA/e 10 DN25: 1.6 - 16 QA/e 16 DN25: 2 - 25 QA/e 25 DN25: 2.5 - 40 QA/e 40 DN25: 3.3 - 65	QA/e 40 DN40: 5 - 65	QA/e 65 DN 50: 6 - 100 QA/e 100 DN 80: 10 - 160 QA/e 160 DN 80: 13 - 250 QA/e 250 DN 100: 20 - 400 QA/e 400 DN 100: 32 - 650 QA/e 400 DN 150: 32 - 650 QA/e 650 DN 150: 50 - 1000 QA/e 1000 DN 150: 80 - 1600				
	Max. error $0.1 Q_{max} - 0.2 Q_{max}$	< 3% vom Messwert (< 1% vom Messbereichsendwert)						
	Max. error $0.2 Q_{max} - Q_{max}$	< 1.5% vom Messwert (< 1% vom Messbereichsendwert)						
Housing	Material	Aluminium						
	Diameter	DN mm	25	40	50	80	100	150
		"	1"	1½"	2"	3"	4"	6"
	Dimensions	A * mm	159	202	202	225	245	300
		C mm	240	190	60	120	150	180
		C1 mm	185	126.5	-	-	-	-
		G * mm	115	150	150	150	165	190
Weight	kg	1	2.2	1.4	5.3	6.8	11.4	
Assembly		In pipes with screw connections according to DIN ISO 228 1" internal thread	In pipes with screw connections according to DIN ISO 228 1 ½" internal thread	Installation between flanges PN 10/16 (DIN EN 1092-1) or ANSI 150				
Outputs/ puls values	LF type E1 Reed switch	10 imp/m³	1 imp/m³	1 imp/m³				
	MF type E200 inductive proximity switch	500 imp/m³ **	250 imp/m³	QA 65 : 250 imp/m³ QA 100 - 650: 187.5 imp/m³ QA/e 100 - 1000: 187.5 imp/m³				

* QAe +25mm ** from 01/01/2002

Pulsers

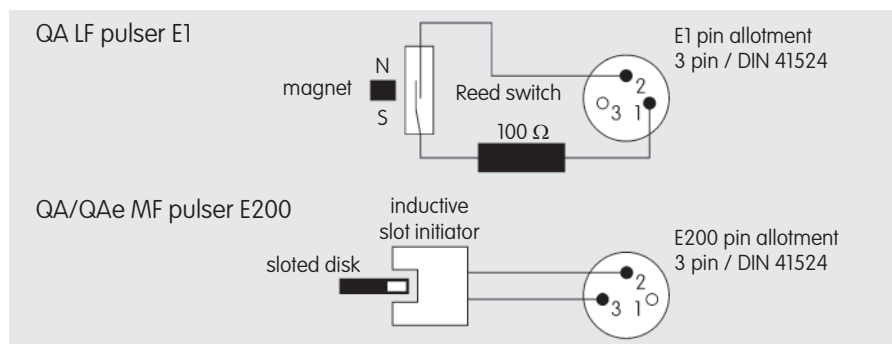

Voltage: $U_{max} = 24 V$
 Current: $I_{max} = 50 mA$
 Capacity: $P_{max} = 0,25 W$
 Resistance: $R_v = 100 \Omega \pm 20\%$

Characteristics of switch version according to DIN EN 50227 (Namur):

Standard voltage: $U_n = 8 V DC$
 Internal resistance: $R_i = 1 k \Omega$
 Current consumption: aktive Fläche frei $I \geq 2,1 mA$
 aktive Fläche bedeckt $I \leq 1,2 mA$