

## Differential Pressure Gauges with Bourdon Tube, Parallel Entry Model 711.12, Measuring System Cu-alloy Model 731.12, Measuring System Stainless Steel

WIKA Data Sheet PM 07.02

### Applications

- Measurement of differential pressures or of two different pressures applied
- Heating, ventilation and air-conditioning
- For gaseous and liquid media that are not highly viscous or crystallising
- Model 731.12 for aggressive media also

### Special Features

- Scale ranges from 0 ... 0.6 bar
- Differential pressure with moving dial
- Economical and reliable



Differential Pressure Gauge Model 711.12

### Description

#### Design

2 independent measuring systems, parallel entries in line

#### Nominal size in mm

100, 160

#### Accuracy class

1.6

#### Scale ranges

0 ... 0.6 to 0 ... 1000 bar

Scale range must be selected in relation to the highest total pressure applied!

In heating plants with circulating pumps, the overall pressure is usually defined as equal to the hydrostatic pressure plus the pump pressure.

In order to ensure a good readability, the pressure differential to be indicated should be no less than 1/6 of the full scale range.

When ordering please state both pressures:

a) maximum pressure applied, b) differential pressure

#### Pressure limitation

Steady: full scale value

Fluctuating: 0.9 x full scale value

Short time: 1.3 x full scale value

#### Operating temperature

Ambient: -20 ... +60 °C

Medium: Model 711.12: +60 °C maximum (soft soldered)  
+100 °C maximum (brazed)

Model 731.12: +200 °C maximum

#### Temperature effect

When the temperature of the measuring system deviates from the reference temperature (+20 °C):  
max.  $\pm 0.4 \%$  / 10 K of full scale value

#### Ingress protection

IP 33 per EN 60 529 / IEC 529

## Standard version

### Process connection

Model 711.12: Cu-alloy

Model 731.12: stainless steel

2 x G 1/2 B, male, 22 mm flats,

plus-connection back, minus-connection front  
(with ⊕ and ⊖ identified)

### Pressure elements

Model 711.12:

< 100 bar: Cu-alloy, C-type, soft soldered

≥ 100 bar: stainless steel, helical type, brazed

Model 731.12:

Stainless steel, all pressure ranges, welded

### Movement

Cu-alloy, wear parts argentan

### Dial

Aluminium, white, lettering black

### Pointer

1 standard pointer: Aluminium, black

1 scale pointer: Aluminium, white  
scaled ±50 % of main scale range

### Case

Steel, black

### Window

Instrument glass

### Bezel ring

Slip-on bezel, Steel, black

## Options

- Other process connection
- Case and bezel ring of stainless steel
- Design with duplex scale („duplex pressure gauge“)
- NS 100: liquid filling (model 713.12),
- NS 100: measuring system, case, bezel ring stainless steel and liquid filling (model 733.02), medium temperature resistant up to max. 100 °C
- Subtracting movement (one pointer for differential pressure scale), location of reversed pressure connection: ⊕-connection front, ⊖-connection back, Cu-alloy or stainless steel
- Panel or surface mounting flange
- Alarm contact (data sheet AC 08.01), subtracting movement

## Dimensions in mm

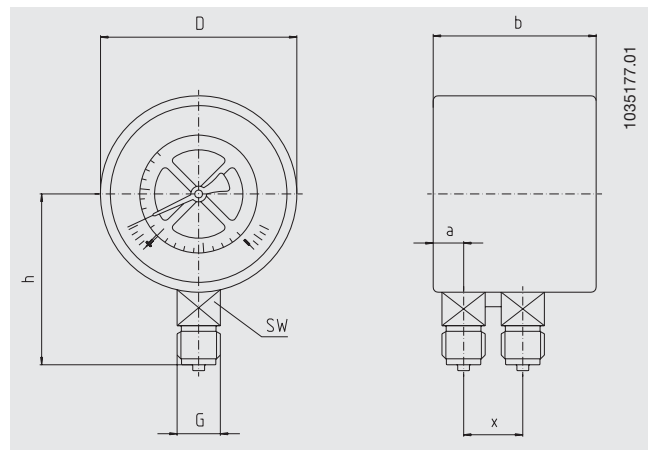

NS	Dimensions in mm						SW	Weight in kg
	a	b	D	G	h ± 1	X		
100	15.5	82	100	G 1/2 B	87	32	22	1.00
160	15.5	86.5	160	G 1/2 B	118	32	22	1.60

Process connection per EN 837-1 / 7.3

## Ordering information

Model / Nominal size / Scale range / Differential or duplex scale / Size of connection / Max. pressure applied / Differential pressure span / Options

Modifications may take place and materials specified may be replaced by others without prior notice.  
Specifications and dimensions given in this leaflet represent the state of engineering at the time of printing.