

Differential Pressure Gauges Model 711.11, with Bourdon Tube Element, Vee Entry

WIKA Data Sheet PM 07.01



Applications

- Measurement of differential pressures or of two different pressures applied
- For gaseous and liquid media that are not highly viscous or crystallising and will not attack copper alloy parts
- Heating, ventilation and air conditioning

Special Features

- Differential pressure with moving dial
- Cost-effective and reliable
- Scale ranges from 0 ... 0.6 bar



Differential Pressure Gauge Model 711.11

Description

Design

Two independent measuring systems, vee entry 60°

Nominal size in mm

100, 160

Accuracy class

1.6

Scale ranges

0 ... 0.6 to 0 ... 60 bar

Scale range must be selected in relation to the highest total pressure applied!

In heating plants with circulating pumps, the overall pressure is usually defined as equal to the hydrostatic pressure plus the pump pressure.

In order to ensure a good readability, the pressure differential to be indicated should be no less than 1/6 of the full scale range.

When ordering please state both pressures:

- maximum pressure applied,
- differential pressure

Pressure limitation

Steady: 3/4 x full scale value
 Fluctuating: 2/3 x full scale value
 Short time: full scale value

Operating temperature

Ambient: -20 ... +60 °C
 Medium: +60 °C maximum

Temperature effect

When the temperature of the measuring system deviates from the reference temperature (+20 °C):
 max. ±0.4 %/10 K of full scale value

Ingress protection

IP 33 per EN 60 529 / IEC 529

Standard version

Process connection

Cu-alloy,
lower mount (LM)
2 x G ½ B (male),
identified ⊕ and ⊖

Pressure elements

Cu-alloy, C-type

Movement

Cu-alloy, wear parts argentan

Dial

Aluminium, white, black lettering
2nd scale in mWS, inside, black

Pointer

1 standard pointer: Aluminium, black
1 scale pointer: Aluminium, white
scaled ±50 % of main scale range as
plus and minus differential pressure
indication

Case

Steel, black

Window

Instrument glass

Bezel ring

Slip-on bezel, steel, black

Options

- Other process connection
- Design with duplex scale ("duplex pressure gauge")
- Panel or surface mounting flange
- Switch contacts (see data sheet AC 08.01), subtracting movement obligatory

Dimensions in mm

Standard version

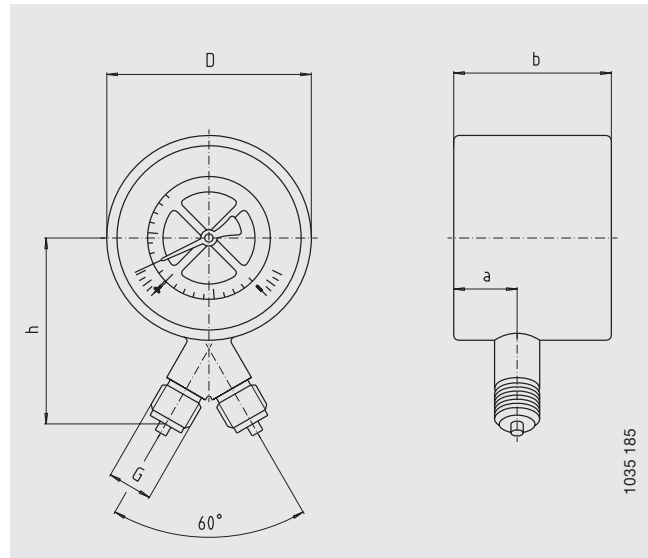

NS	Dimensions in mm					Weight in kg
	a	b	D	G	h ± 1	
100	31.5	82	101	G ½ B	91	1.00
160	31.5	86.5	160	G ½ B	120	1.60

Process connection per EN 837-1 / 7.3

Ordering information

Model / Nominal size / Scale range / Differential or duplex pressure indication / Max. pressure applied / Differential pressure span / Connection size / Options

Modifications may take place and materials specified may be replaced by others without prior notice.
Specifications and dimensions given in this leaflet represent the state of engineering at the time of printing.