

AUTOMATEC
C'EST FLUIDE CONTRÔLE

NOCTAN
AUTOMATISMES ET
CONTRÔLE DES FLUIDES



**MESURE REGULATION
HYDRAULIQUE
PNEUMATIQUE
ROBINETTERIE**

LE SPÉCIALISTE DU CONTRÔLE DES FLUIDES

ECLIPSE® AURORA™



Installation and Operating Manual

For the Magnetic Level Indicator (MLI) and Level Switches



*Guided Wave Radar
and
Magnetic Level Indication
for
Redundant Level
Measurement*

7xxx

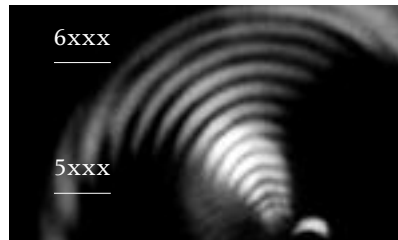

6xxx

5xxx

4xxx

3xxx

2xxx

1xxx

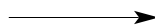

Magnetrol®

UNPACKING

Unpack the instrument carefully. Make sure all components have been removed from the foam protection. Inspect all components for damage. Report any concealed damage to the carrier within 24 hours. Check the contents of the carton/crates against the packing slip and report any discrepancies to Magnetrol. Check the nameplate model number (Model number/approvals as per inserted separate sheet) to be sure it agrees with the packing slip and purchase order.

The Eclipse® Aurora™ model number defines:

- The Magnetic Level Indicator.
- The Eclipse® Guided Wave Radar transmitter and switches/transmitters: each of these components have their own model number that refers to their own approvals / instruction manuals (as per separate inserted documents).

Check and record the Eclipse® Aurora™ serial number for future reference when ordering parts.

Pre-installation checklist:

- Verify if the units' center to center distance equals the center to center distance of the vessel.
- Locate the external mounted switches/transmitters. These are separately packed (for proper mounting/installation; see included instruction manuals).
- Locate the Eclipse® amplifier head (for proper mounting/installation – see Eclipse® instruction manual).

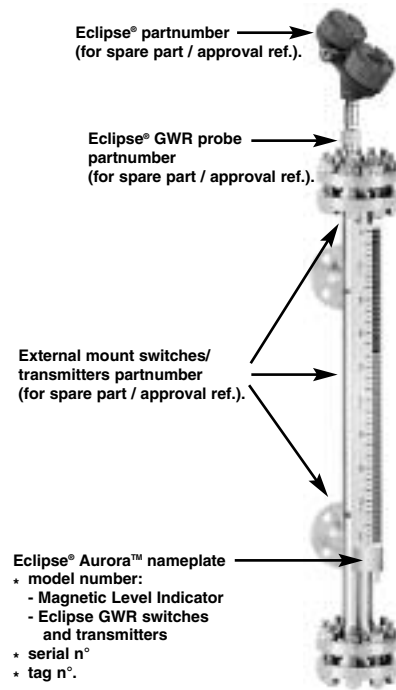

CAUTION: When handling longer units, assure that these are supported over the entire length to avoid bowing causing deformation / glass breakage.

MOUNTING – Magnetic Level Indicator

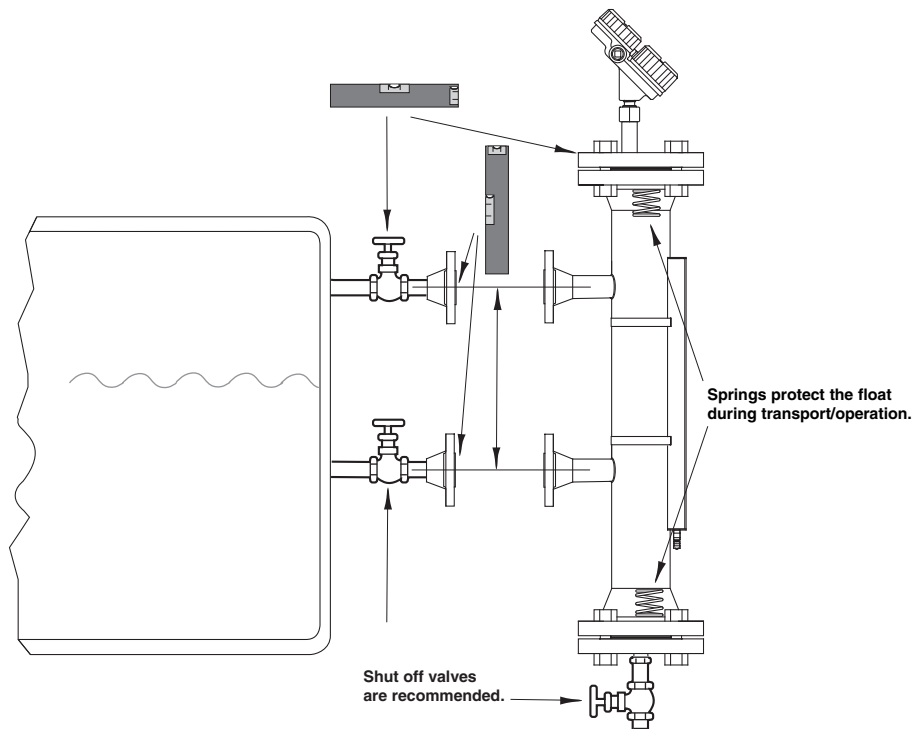

Note: The float and the guided wave radar probe are pre-mounted into the magnetic level indicator. The float is protected against transport damage and operational conditions by means of internal springs.

CAUTION: In case shut off valves are used, care must be taken when opening the valves to prevent a surge of fluid and gases through the chamber. A surge can cause the float to be propelled to the far end of the chamber, and float damage could result.

MOUNTING – Magnetic Level Indicator

Reassembly guidelines

Reassembly guidelines for the float / GWR probe in case these need to be dismantled for eg. cleaning of the cage:

- Verify that the "TOP" marking on the float is pointing upwards when re-installing.
- Make sure that the float is positioned in between the cage wall and the baffle plate, when re-installing.
- Verify that the GWR probe is installed the farthest away from the flapper rail.
- Assure proper sealing of the gaskets.

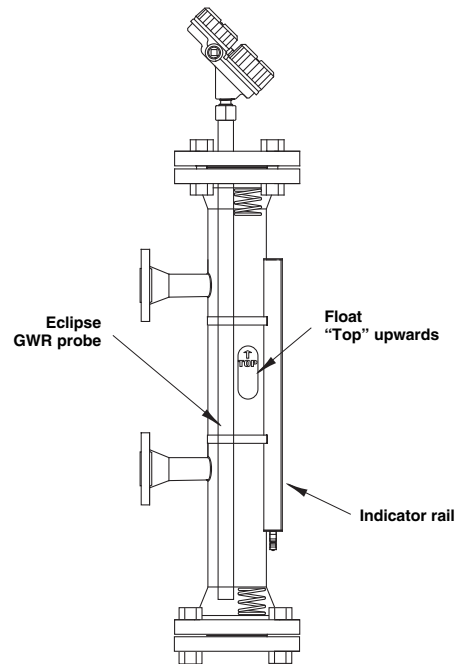
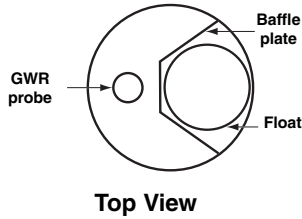

CAUTION: Do not reposition the indicator rail from its original delivered position. Repositioning of the rail may disrupt the magnetic coupling between the float's magnet and the flappers in the indicator rail (and any other magnetic coupled equipment with the float e.g. external mount switches).

MOUNTING – Eclipse amplifier

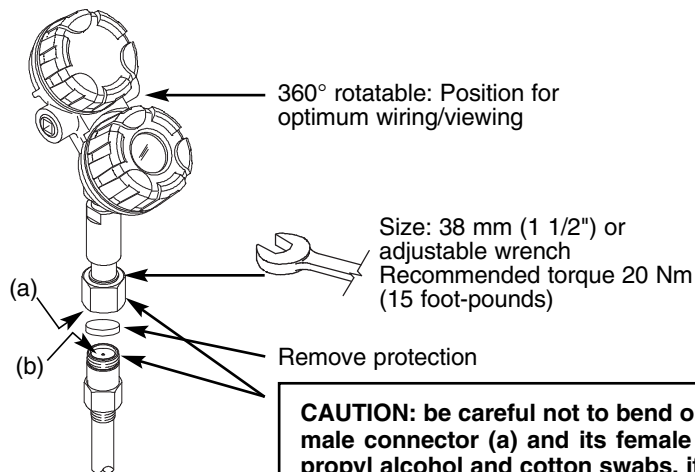

CAUTION: be careful not to bend or dirty the gold, high frequency male connector (a) and its female connector (b). Clean with iso-propyl alcohol and cotton swabs, if necessary

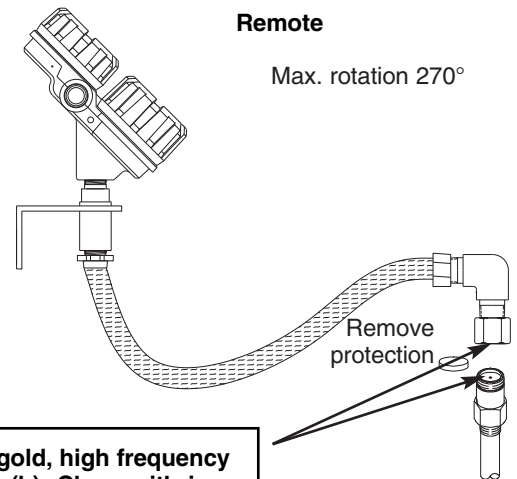

TROUBLESHOOTING

Problem

Solution

Flags do not rotate with level change.

Test flags with a magnet from bottom to top (magnet not included). If flags test O.K, check for float obstruction (see maintenance).

Switch does not actuate with level change.

Check micro switch for continuity. Replace if damaged, if O.K, remove switch from piping column and test switch magnet assembly with re-alignment magnet, by moving magnet over the housing face. If the switch magnet assembly fails to respond, replace the switch. If the switch checks O.K, check float travel.

Reed transmitter does not track level.

Remove transmitter assembly from piping column and test with re-alignment magnet. Run magnet from bottom to top of reed chain. Check zero and span calibration. If no change in output, replace.

Flags rotate at different height than actual level.

Float selected for different specific gravity. Replace float with a float with correct specific gravity rating. Confirm correctness of float orientation. Top is up.

Float inside the level gauge is moving slow or not at all.

Make sure the MLI is level vertically.

The process fluid being measured may be too viscous and heat tracing may be required to make the material more fluid. Heat tracing can be purchased from the factory.

The specific gravity of the process fluid and the float weight may need to be reverified.

The liquid being measured may contain magnetic particles collecting on the magnetic section of the float causing drag. If this happens, magnetic trap assemblies can be purchased from the factory.

Visual inspection of the float may be required to see if the float has collapsed.

Scale is at zero to the center of the bottom process connection, but the indicator is above or below zero.

The scale assembly is mounted to the chamber using stainless steel gear clamps. It can be easily adjusted in the field using a screwdriver. Make sure the scale zero is in line with the center of the process connection.

The float stop spring at each end of the chamber is there to cushion as well as position the float assembly to the center of the process connection. Make sure top or bottom float stop springs are not bent or broken.

Indicator has uncoupled and fallen to the bottom of the glass tube.

In some "flashing" applications, the float may rise or fall quickly. Consult factory for suggestions to help avoid this.

To re-couple the indicator to the float, simply use a small magnet and run it along the length of the chamber to locate the float. Mark the location of the float on the outside chamber. Use the small magnet to couple with the indicator and pull the indicator up to meet and couple with the float.

Make sure all stainless steel gear clamps are tight. The scale channel must be tight against the chamber.

** Assure unit installation is level.*

MAINTENANCE

If the process liquid is clean (no solids or deposits), the MLI should require minimum maintenance. If the process liquid is dirty (solids and deposits), it is recommended the external cage be isolated from the process and flushed periodically. For complete cleaning, after draining the unit, remove the bottom flange and float, inspect cage and float for build up and clean if required.

Magnetic traps are available to prevent magnetic particulate travel from the vessel to the chamber.

REPLACEMENT PARTS

For the magnetic level indicator: consult factory.

For the Eclipse Guided Wave Radar: consult instruction manual BE 57-600

MAGNETIC LEVEL INDICATOR – SPECIFICATIONS

Measured value	Liquid level (consult factory for liquid-liquid interface)	
Measuring range	From 300 mm (11.81") up to 5700 mm (224")	
Indicators	Metal flag (red/white) – all indicators are hermetically sealed and assured by the "Insta-Seal" technology	
Scale	In cm or % of span	
Specific gravity	As low as 0.5 kg/dm ³	
Visual indication	Visible from a distance up to 30 m (100 feet)	
Float	Type	With magnetic flux ring – assembly – see page 2
	Materials	316 SST (1.4401), Titanium, others at request
Cage	Materials	316/316L SST (1.4401/1.4404), others at request
	Size	3" or 4" depending configuration
	Rating	Up to 2500 lbs / PN 320 class ratings
	Configuration	Side/side connection with 1/2" NPT plugged vent and drain
Insulation material	Weather resistant silicone cloth (high temperature application) Polyurethane + aluminium jacket with polymeric frost extension for flag-rail (cryogenic application)	
Process connections	Threaded, socket welded or flanged	
Design	All cages are designed to meet the European PED (Pressure Equipment Directives) 97/23 EC guidelines	
Constructions	Standard commercial design NACE construction Others at request: eg. IBR, ASME - ANSI B31.3	

MODEL IDENTIFICATION – CROSS REFERENCE PARTNUMBERS ECLIPSE AURORA

The Eclipse Aurora partnumber defines the Eclipse transmitter and the GWR probe partnumbers into one model code. The original model code of the Eclipse electronics should be used for approval and spare part reference of the electronics. This number is available on the nameplate of the Eclipse transmitter (see page 2) or you can use the below cross reference part-number to rebuild the equivalent Eclipse partnumber from the Eclipse Aurora partnumber.

**TRANSMITTER & GWR PROBE
Electronics**

7 3
7 4
7 5
7 6

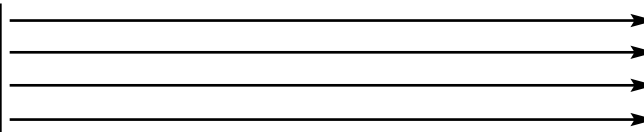

**TRANSMITTER
Electronics**

7 0 5	5 1 0 0
7 0 5	5 1 0 A
7 0 5	5 2 0 0
7 0 5	5 2 0 A

Mounting/Classification

1
2
A
B
C
D
E
F



Mounting/Classification

1
2
A
B
C
D
E
F

Housing

1
2
3
4

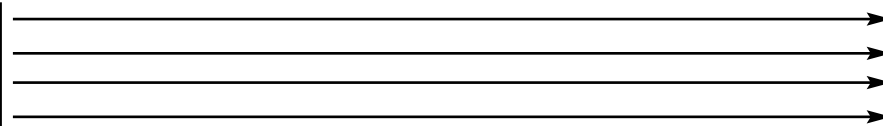

Housing

1 0
1 1
2 0
2 1

7	0	5	5	*	0	*	*	*	*
---	---	---	---	---	---	---	---	---	---

GWR Probe Type

R
D
S

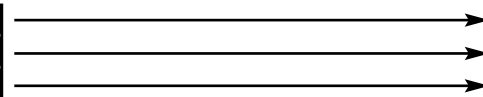

GWR Probe Type

X 7 M R
X 7 M D
X 7 M S

Probe Material

A
B
C

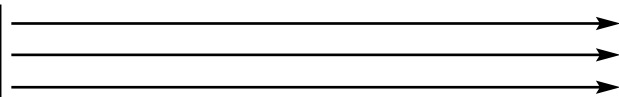

Probe Material

A
B
C

Process connection

* * defined by magnetic level indicator P/N

Process Seal-Material

0
1
2
N
8

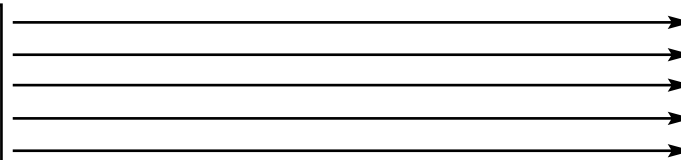

Process Seal-Material

0
1
2
N
8

Measuring Range

* * *

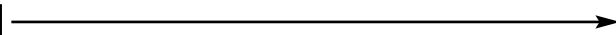

Probe length

* * *

7	*	*	*	*	*	*	*	*	*
---	---	---	---	---	---	---	---	---	---

X	7	M	*	*	*	*	*	*	*
---	---	---	---	---	---	---	---	---	---

7	0	5	5	*	0	*	*	*	*
---	---	---	---	---	---	---	---	---	---

DIMENSIONS in mm (inches)

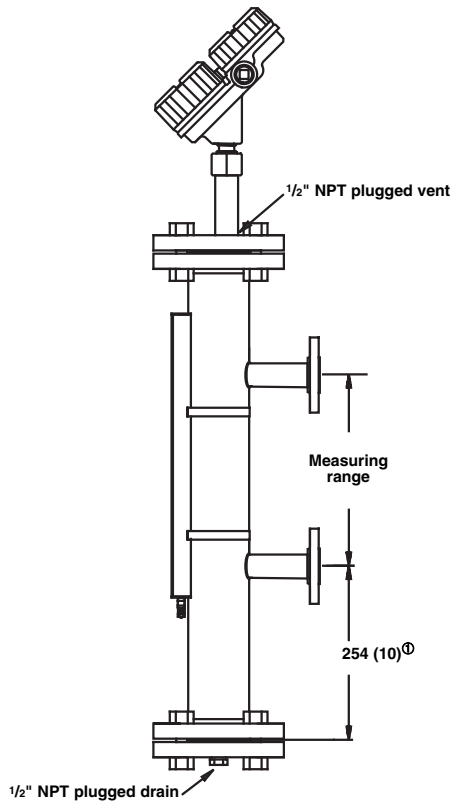

Flanged

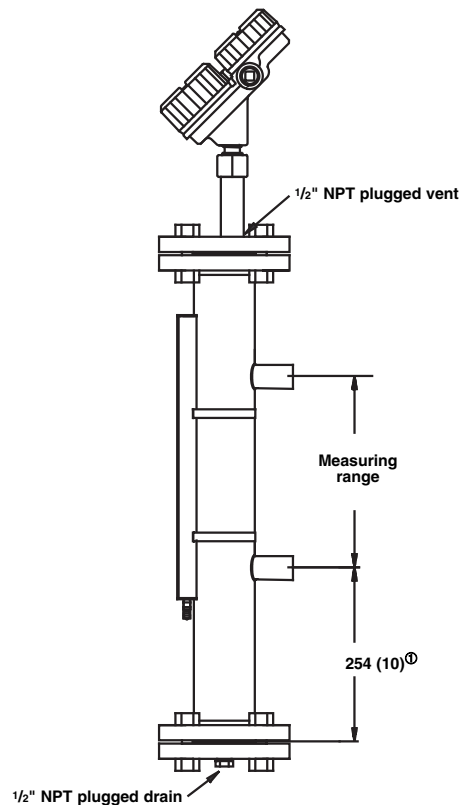

Threaded/Welded

① For S.G. < 0.8 and/or flange rating > 1500 lbs / PN 250, dimension will increase

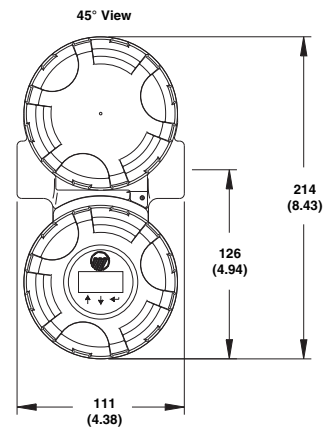
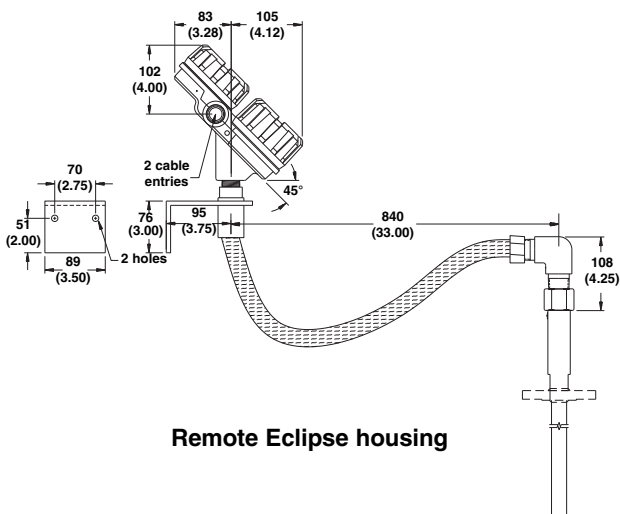

**Eclipse Housing,
(45° View)**

IMPORTANT

SERVICE POLICY

Owners of Magnetrol products may request the return of a control; or, any part of a control for complete rebuilding or replacement. They will be rebuilt or replaced promptly. Magnetrol International will repair or replace the control, at no cost to the purchaser, (or owner) **other than transportation cost** if:

- a. Returned within the warranty period; and,
- b. The factory inspection finds the cause of the malfunction to be defective material or workmanship.

If the trouble is the result of conditions beyond our control; or, is **NOT** covered by the warranty, there will be charges for labour and the parts required to rebuild or replace the equipment.

In some cases, it may be expedient to ship replacement parts; or, in extreme cases a complete new control, to replace the original equipment before it is returned. If this is desired, notify the factory of both the model and serial numbers of the control to be replaced. In such cases, credit for the materials returned, will be determined on the basis of the applicability of our warranty.

No claims for misapplication, labour, direct or consequential damage will be allowed.

RETURNED MATERIAL PROCEDURE

So that we may efficiently process any materials that are returned, it is essential that a "Return Material Authorisation" (RMA) form will be obtained from the factory. It is mandatory that this form will be attached to each material returned. This form is available through Magnetrol's local representative or by contacting the factory. Please supply the following information:

1. Purchaser Name
2. Description of Material
3. Serial Number and Ref Number
4. Desired Action
5. Reason for Return
6. Process details

All shipments returned to the factory must be by prepaid transportation. Magnetrol **will not accept** collect shipments.

All replacements will be shipped FOB factory.

UNDER RESERVE OF MODIFICATIONS

BULLETIN N°: BE 57-638.2
EFFECTIVE: NOVEMBER 2005
SUPERSEDES: May 2002



www.magnetrol.com

BENELUX	Heikensstraat 6, 9240 Zele, België Tel. +32 (0)52.45.11.11 • Fax. +32 (0)52.45.09.93 • E-Mail: info@magnetrol.be
DEUTSCHLAND	Alte Ziegelei 2-4, D-51491 Overath Tel. 02204 / 9536-0 • Fax. 02204 / 9536-53 • E-Mail: vertrieb@magnetrol.de
FRANCE	40 - 42, rue Gabriel Péri, 95130 Le Plessis Bouchard Tél. 01.34.44.26.10 • Fax. 01.34.44.26.06 • E-Mail: magnetrolfrance@magnetrol.fr
ITALIA	Via Arese 12, I-20159 Milano Tel. (02) 607.22.98 (R.A.) • Fax. (02) 668.66.52 • E-Mail: mit.gen@magnetrol.it
UNITED KINGDOM	Unit 1 Regent Business Centre, Jubilee Road Burgess Hill West Sussex RH 15 9TL Tel. (01444) 871313 • Fax (01444) 871317 • E-Mail: sales@magnetrol.co.uk
INDIA	E-22, Anand Niketan, New Delhi - 110 021 Tel. 91 (11) 41661840 • Fax 91 (11) 41661843 • E-Mail: info@magnetrolindia.com

NOS IMPLANTATIONS



ILE-DE-FRANCE
85 ROUTE DE GRIGNY
91136 RIS ORANGIS
• TÉL. 01 69 25 91 21
• FAX. 01 69 25 98 60
• p.besse@groupe-tc.com

HAUTE NORMANDIE
SDM THERMIQUE ET CONTRÔLE
22 RUE DES PÂTIS - BP 292
76143 LE PETIT-QUEVILLY CEDEX
• TÉL. 02 32 81 87 87
• FAX. 02 32 81 87 88
• gtdot@groupe-tc.com

HAUTE NORMANDIE
SDM PORTE OcéANE
192 RUE DE LA VALLÉE
76600 LE HAVRE
• TÉL. 02 35 24 40 55
• FAX. 02 35 53 31 06
• b.duhamel@groupe-tc.com

NORD PAS DE CALAIS
SDM NORD INSTRUMENTATION
RUE DES FAMDARS - BP 224
59812 LESQUIN CEDEX
• TÉL. 03 20 18 08 40
• FAX. 03 20 18 08 41
• p.carnoy@groupe-tc.com

GROUPE
THERMIQUE & CONTRÔLE

www.groupe-tc.com



PAYS DE LA LOIRE
ZONE D'ACTIVITÉ
DE LA MAISON NEUVE
6 RUE CLÉMENT ADER - BP 83
44984 STE LUCE-SUR-LOIRE
CEDEX
• TÉL. 02 51 85 09 90
• FAX. 02 51 85 00 08
• automatec@groupe-tc.com

BASSE NORMANDIE
9 RUE DE BRÉHOLLES - BP 34
14540 SOLIERS
• TÉL. 02 31 15 54 54
• FAX. 02 31 15 54 55
• g.guilbert@groupe-tc.com

BRETAGNE
159 IMPASSE A. RHIUYS
ZI DE KERPOINT
56850 CAUDAN
• TÉL. 02 97 81 05 42
• FAX. 02 97 81 35 61
• s.barille@groupe-tc.com

PARTENAIRES DISTRIBUTEURS

NOS PARTENAIRES

MESURE • RÉGULATION

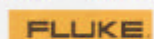

PNEUMATIQUE



HYDRAULIQUE



ROBINETTERIE

