

THREE-CHANNEL PEN RECORDER KR5A



144 X 144 X 284 mm

SERVICE MANUAL



CONTENTS

page

1. APPLICATION	4
2. SET OF THE KR5A RECORDER	4
3. BASIC REQUIREMENTS, OPERATIONAL SAFETY	5
4. PRINCIPLE OF OPERATION	7
5. DESIGN	10
6. RECORDER INSTALLATION	15
6.1. Fitting in the panel	16
7. PUTTING THE RECORDER INTO OPERATION	18
7.1. Removing from the housing	18
7.2. Preparation to work	19
8. RECORDER SERVICING	20
8.1. Recorder chart replacement	20
8.2. Pen replacement	21
8.3. Lubrication	22
8.4. Recorder control	23
8.4.1. Alarm control	23
8.4.2. Calibration of the measuring channel	24
8.4.3. Correction of the sensitivity of the measuring system	24
8.4.4. Correction of the pen adjustment	25
8.4.5. Control of the pen exit	26
9. TECHNICAL DATA	27
10. EXECUTION CODES AND ORDERING	31
11. MAINTENANCE AND GUARANTEE	32

1. APPLICATION

The three-channel compensatory pen recorder of KR5A type is designed for the continuous recording and measurement of slow changing d.c. current and d.c. voltage signals, temperature and resistance changes in three different measuring channels.

It co-operates directly with voltage and current sources, thermocouples (TC) and resistance thermometers (RTD).

The KR5A recorder is especially recommended to be used in systems where continuity of measured variables is required. That recorder can be used as a signal transmitter 0...5 V or 0...20 mA (in each channel independently) which the value is proportional to the measured signal or as an event recorder (1...4 pens).

2. SET OF THE KR5A RECORDER

1. Bottle with oil	1 pc
2. Fuse element WTA T 200 mA/250V	1 pc
3. Pens (depending on recorder execution)	1 set
4. Door keys	2 pcs
5. Service manual	1 pc
6. Guarantee card	

3. BASIC REQUIREMENTS, SAFETY INFORMATION

Symbols located in this service manual mean:



WARNING!

Warning of potential, hazardous situations.

Especially important. One must acquaint with this before connecting the recorder. The non-observance of notices marked by these symbols can occasion severe injuries of the personnel and the damage of the recorder.



CAUTION!

Designates a general useful note. If you observe it, handling of the recorder is made easier.

One must take note of this when the recorder is working inconsistently to the expectations.

Possible consequences if disregarded.

In the security scope the recorder meets the requirements of the EEC Low-Voltage directive (EN 61010-1 issued by CENELEC).

Remarks concerning the operator safety:

1. General

- The KR5A recorder is destined to be mounted on a panel.
- Non-authorized removal of the required housing, inappropriate use, incorrect installation or operation creates the risk of injury to personnel or damage to equipment. For more detailed information please see the service manual.
- All operations concerning transport, installation, and commissioning as well as maintenance must be carried out by qualified, skilled personnel and national regulations for the prevention of accidents must be observed.
- According to this basic safety information, qualified, skilled personnel are persons who are familiar with the installation, assembly, commissioning, and operation of the product and who have qualifications necessary for their occupation.

2. Transport, storage

Please observe the notes on transport, storage and appropriate handling. Observe the climatic conditions given in Technical Data.

3. Installation

- The recorders must be installed according to the regulation and instructions given in this service manual.
- Ensure proper handling and avoid mechanical stress.

- Do not bend any components and do not change any insulation distances.
- Do not touch any electronic components and contacts.
- Recorders contain electrostatically sensitive components, which can easily be damaged by inappropriate handling.
- Do not damage or destroy any electrical components since this might endanger your health!

4. Electrical connection

- Before switching the recorder on, one must check the correctness of connection to the network.
- In case of the protection terminal connection with a separate lead one must remember to connect it before the connection of the recorder to the mains.
- When working on live recorders, the applicable national regulations for the prevention of accidents must be observed.
- The electrical installation must be carried out according to the appropriate regulations (cable cross-sections, fuses, PE connection). Additional information can be obtained from the service manual.
- The documentation contains information about installation in compliance with EMC (shielding, grounding, filters and cables). These notes must be observed for all CE-marked products.
- The manufacturer of the measuring system or installed devices is responsible for the compliance with the required limit values demanded by the EMC legislation.

5. Operation

- Measuring systems including recorders must be equipped with protection devices according to the corresponding standard and regulations for prevention of accidents.
- After the recorder has been disconnected from the supply voltage, live components and power connections must not be touched immediately because capacitors can be charged.
- The housing and the door must be closed during operation.

6. Maintenance and servicing

Please observe the manufacturer's documentation. Read all product-specific safety and application notes in this service manual.

- Before taking the recorder housing out, one must turn the supply off.
- The removal of the recorder housing during the warranty contract period may cause its cancellation.

4. PRINCIPLE OF OPERATION

The recorder includes the following basic electronic blocks (fig. 1)

- range insert (WZ),
- feeder (Z),
- alarm system (A),
- amplifier (W), with a follow-up d.c. motor,
- linear measuring potentiometer (Pp)

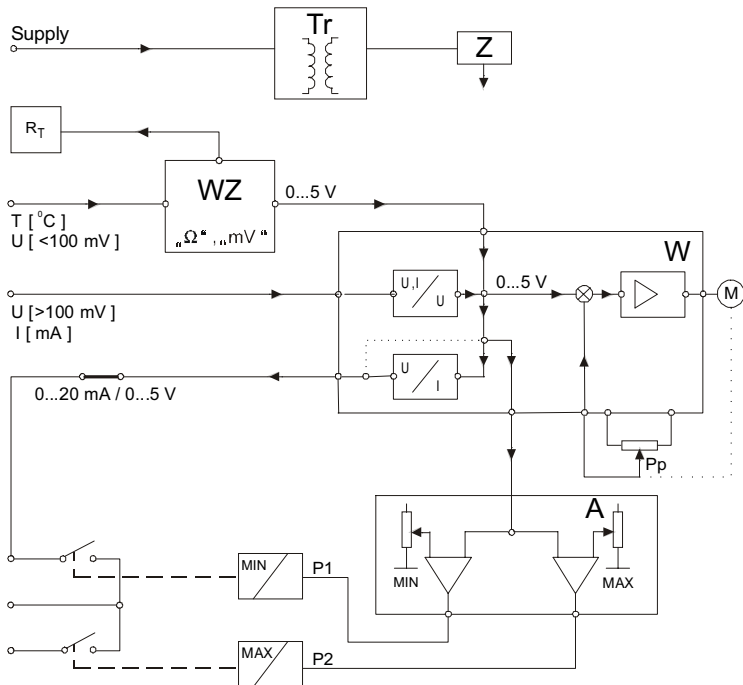

Fig. 1.

Two basic inserts are accessible and adapted to measure:

- a) temperature, with a thermocouple, with or without linearization of the characteristic and d.c. voltage till 100 mV.
- b) temperature, with a resistance thermometer, with or without linearization of the characteristic, connected by a two or four-wire connection and after changing the potentiometer transmitter resistance.

The measured input signal (d.c. voltage, d.c. current, resistance thermometer resistance alterations), thermocouple voltage, potentiometer transmitter resistance alterations is converted in the range insert (WZ) into a d.c. voltage varying within 0...5 V, proportionally to input signal alterations.

This 0...5 V standard voltage is directly introduced as a retransmitting signal to the input recorder terminals or - after converting, as a proportional 0...20 mA current value.

While measuring temperature by thermocouple (fig. 2) it is possible to work with an automatic cold junction temperature compensation system (ACJC) - A cooper resistor $R_T = \text{Cu } 100$, at 25°C , is mounted close to input recorder terminals as a compensating element.

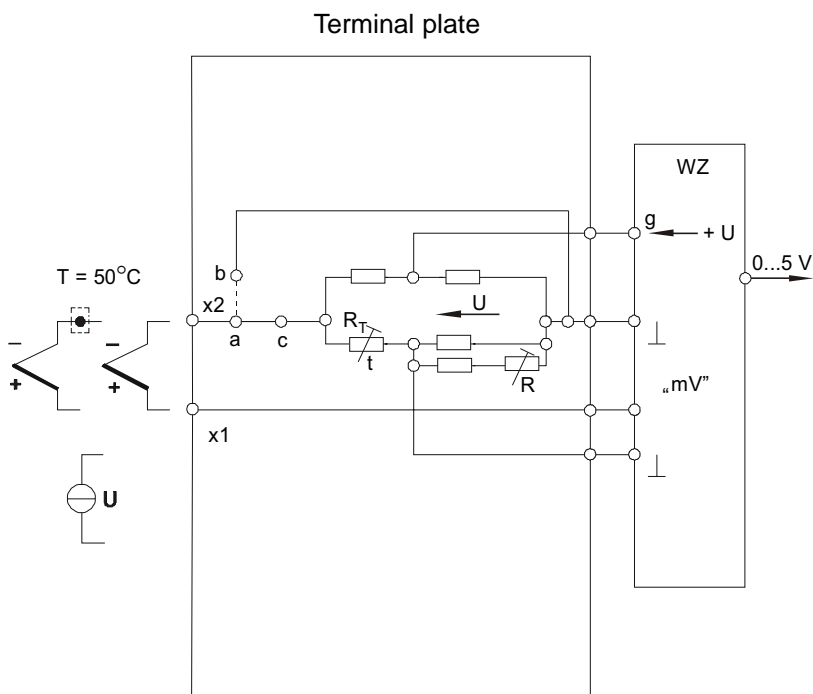

a - b connected - Voltage measurement

Fig. 2.

The bridge configuration which includes the R_T resistance is supplied from the range insert. While connecting the thermocouple to the reference junction being in a constant temperature $+50^\circ\text{C}$, we replace the R_T resistance by a constant

resistor and the voltage from the bridge compensates the reference junction voltage corresponding to the specified $+50^{\circ}\text{C}$ temperature. The range insert for the resistance thermometer temperature measurement is adapted to a two or four-wire connection. (fig.3).

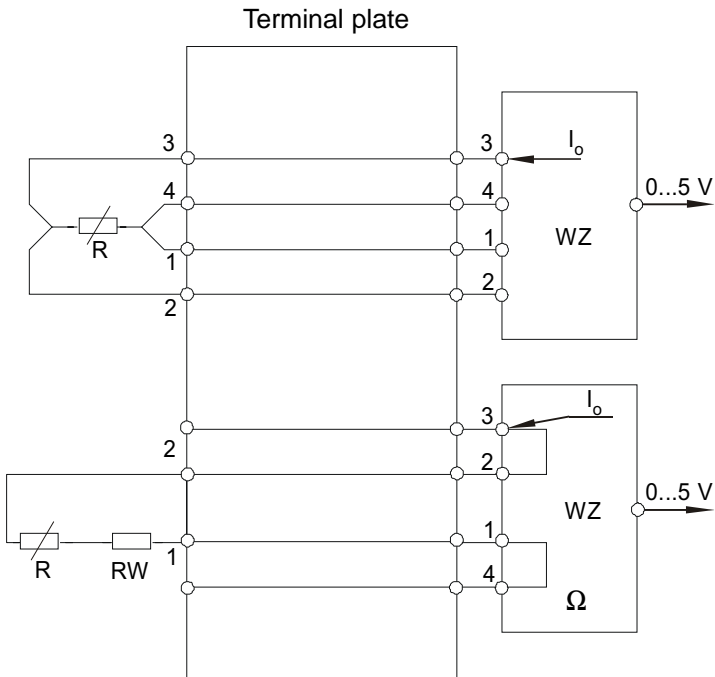

Fig. 3.

In case of a two-wire connection of the resistance thermometer we must connect in series a balancing R_w resistor which establishes $10\ \Omega$ resistance of the supplying line.

In case of a four-wire connection of the resistance thermometer, the supplying line resistance value is compensated in the input circuit of the range insert. The $0\text{...}5\ \text{V}$ output voltage from the range insert or from the amplifier input circuit is compared with the U_p voltage from the measuring potentiometer P_p . The difference of voltages after amplifying controls the follow-up motor (M) coupled with the potentiometer slider and the pen.

The movement of the potentiometer slider with the pen lasts till the moment of equalization between the two voltages. The output $0\text{...}5\ \text{V}$ voltage from the range insert or from the amplifier input circuit is compared in the alarm system (A)

to the set standard voltages MIN and MAX which values corresponding to the operating signalling points. When these voltages are equalized and the system is being operational, this bring about the lighting of appropriate light-emitting diodes situated - on the left side for MIN and on the right side for MAX. Also the shorting or opening of relay contacts led out to the recorder terminal plate follows. In each channel, on account of utilizing the same terminals, an alarm system or interchangeably - led out a retransmission signal may be built-in.

5. DESIGN

The KR5A type recorder is a three-channel compensatory continuous recorder designed for recording measured magnitudes on a recording paper tape. The recorder housing (1) made of steel sheet is closed from the frontal side with a transparent door (2) with a lock.

Inside the housing, the recorder is fixed with the help of a catch. The recorder is mounted in a panel with the use of two screw holders installed in the housing sockets.

In the rear side of the housing there is a terminal plate (5) with stanchions (6) to which a cover with earth terminals (4) is screwed. These terminals are designed to join signalling conductor screens connected to input measuring terminals of the recorder with the earthed housing.

On the terminal plate, following terminals are placed: input terminals for three measuring channels (7) (or terminals for 1...4 event markers and two measuring channels), alarm terminals or output signals (8) and supply terminals (9).

A printed circuit, with microswitches short-circuiting connected current measuring circuits of the recorder, is screwed to the terminal plate from the recorder frontal side.

A universal winding assembly of the recording roll and Z-fold chart (3) is fixed in the frontal part of the recorder.

The removal of this winding assembly from the recorder and the chart replacement is described in the point 8.1.

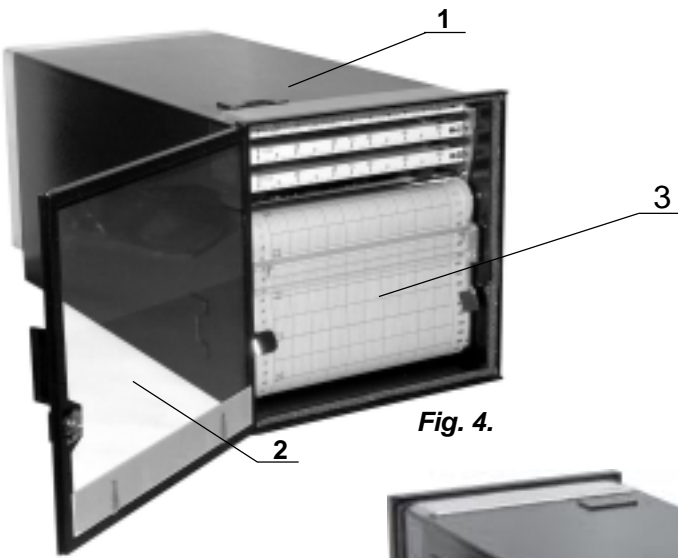

Fig. 4.



Fig. 5.



Fig. 6.

Behind the winding assembly the winding drive assembly with a seven or eight-step gear box (10) is situated, depending on the recorder execution. The setting of the required speed is realised by the displacement of the toothed wheel (11). The speed value is given on the plate placed above the toothed wheel. The chart drive mechanism is protected against overload by a friction clutch situated inside the toothed wheel.



Fig. 7.

Near by the winding assembly, measuring range inserts (12) and alarm packs for particular measuring channels are situated. Above the winding assembly there is the main switch (13) and the fuse (14).

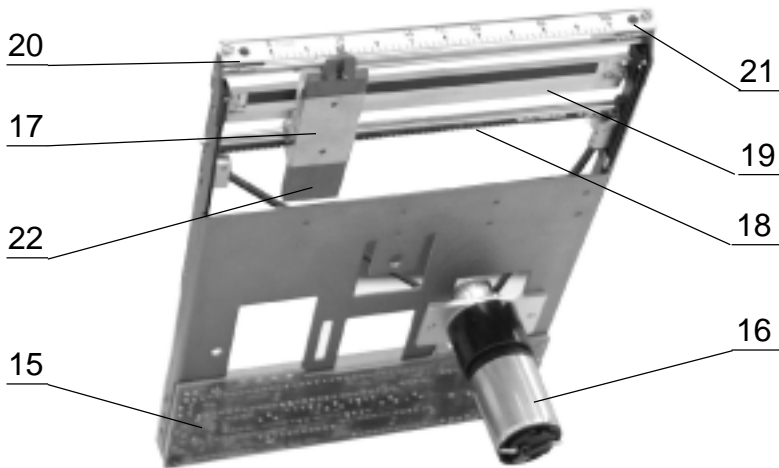

Fig. 8

The recording assembly is made as a bloc which consists of a pack of measuring and control system (15), a d.c. motor with a reduction gear (16), a carriage (17) driven by a motor and a toothed strap (18), a feedback potentiometer (19) and the indicating dial (20). On the both ends of the dial there are alarm diodes (21): left - **Min**, right - **Max**.

A long-life plug-in fibre tipped pen with an ink fount (22) is inserted in the carriage grip. In the recorder execution with the event marker, the 1...4 event marker assembly (23) is situated in the place of the first measuring channel assembly.

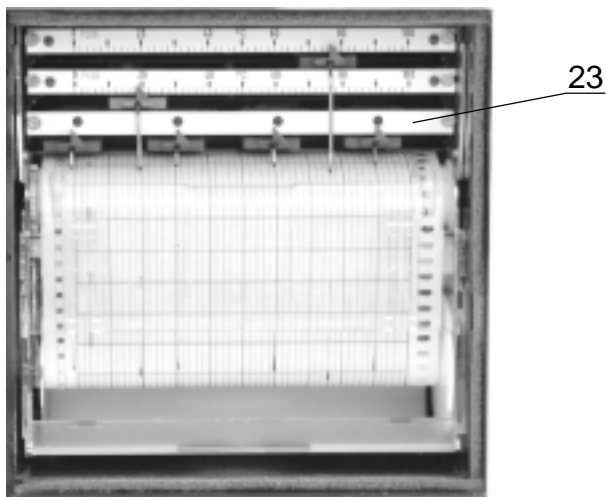

Fig. 9

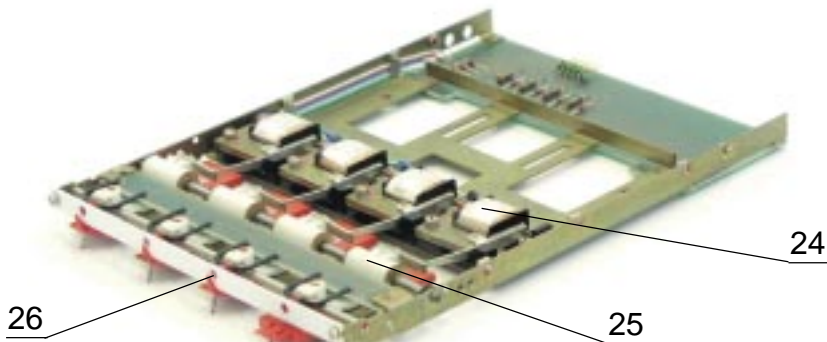

Fig. 10

Electromagnets (24) switched externally, produce a deflection of the carriage with the pen (25) drawing a continuous line along the recording chart. Before each carriage a diode (26) signalling the event working state is situated.

Measuring and event marker assemblies are connected with the terminal plate through the bus pack (27) with the pin (28). Depending on the execution, a bus pack for three measuring channels or a bus pack for two measuring channels and the 1...4 event marker assembly is mounted in the recorder.

Two alarm relays (MIN, MAX) (29) for each measuring channel and elements of the recorder supply system are situated on the bus pack. A supplying transformer (31) and elements guiding the recorder inside the housing (32) are fixed on the rear wall (30).



Fig. 11

6. RECORDER INSTALLATION



Remove the recorder with its accessories with caution from the package.

Unpack the screw holders to mount the recorder in the panel.

The KR5A recorder fulfils suitable requirements concerning the servicing safety and resistance against disturbances occurring in industrial environment. Different disturbance sources occurring in environment practically influence the recorder in a continuous way or in a pulse way from the side of the supplying network (because of the action of other devices) and also superpose on the measuring signal or on the auxiliary circuits of the recorder. Disturbances also arise when switching capacitive-inductive loads through own recorder alarm relays. High impulse disturbances are particularly dangerous for device operation, since they can cause sporadic erroneous measuring results or incidental alarm operations despite the installation of appropriate filters in the recorder. The level of these disturbances should be reduced to a value lower than the recorder resistance threshold, first of all through a suitable recorder installation on the object.

It is recommended to respect following principles:

- Do not supply recorders from the network near devices generating high pulse disturbances in the supply network and do not use common earth circuits with them.
- Apply network filters for the group of recorders servicing the same object.
- To lead supply wires (phase, zero), use metallic screen in the shape of tubes or braids, in which one can lead the earth conductor and also alternatively conductors supplying contacts of alarm relays to the given recorder.
- Conductors leading up the measuring signal to the measuring channel of the recorder should be twisted in pairs and for resistance thermometers in a three-wire connection twisted with conductors of the same length, section and resistance and led in a screen as above.
- All screens should be earthed unilaterally next the recorder.
- One must avoid to use a common earth conductor with other devices.
- Apply the general principle, that conductors (group of conductors) leading different signals should be led in the farthest possible distance from each other and crossings of such groups executed at right angle.

PRECAUTIONS TO PROTECT AGAINST ELECTROSTATIC DISCHARGES (ESD)



Semiconductor elements used in the recorder design, packages marked as above, can be damaged in the result of static electricity discharges (ESD).

In order to prevent damages one must observe following recommendations during routine maintenance:

- Disassemble recorders only i a zero protected area against static electricity discharges.
- In the working zone, use conducting materials in order to electrostatic charge dissipation.
- For electronic elements and package storage use only antielectrostatic packagings.
- Touch as little as possible elements and packages with hands.
- Do not store in the working zone materials susceptible to generate electrostatic charges in the working zone.

6.1. Installation in the panel

The recorder is mounted in the pannel with the use of two screw holders installed in the housing sockets. The sockets arrangement on four housing faces and the special door design allows mounting the recorders being in contact in the pannel.

Overall and cut-out dimensions are shown on the fig. 12.

On the fig. 13, the wiring diagram is shown and the way we connect the power supply and different signal sources.

The power supply wires should be conducted through a separate choke.

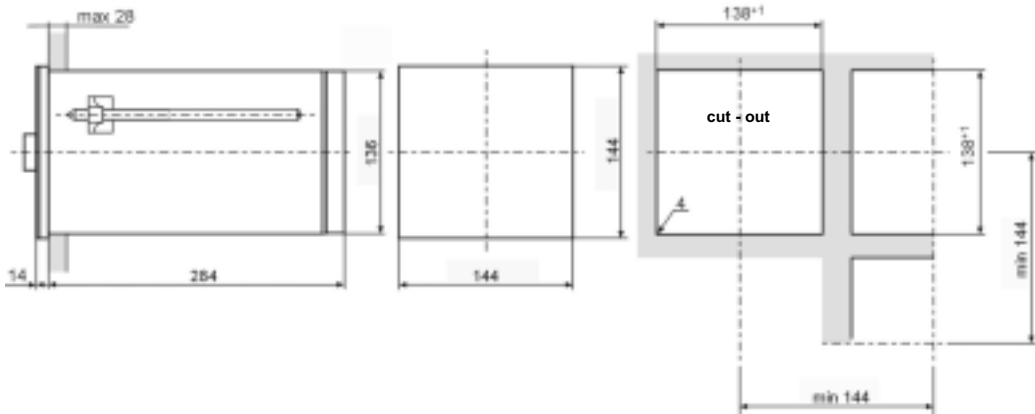

Fig. 12. Overall and assembly dimensions

Measuring signals connection		Recorder No							
Channel No	Range No	U			~ / -				
		J			~ / -	CURRENT SUPPLY			
		T				L	N	E	
		R _T				230 V	110 V		
						50 Hz	50 Hz		
		R _T				ALARM			
		P				MIN	MAX		
				Z / R	Z / R				
	Marker				Retrans. signal 0...20 mA/400Ω 0...5 V/1mA		a - b - c jointer		
I	Terminal No	11	12	13	14	15		16	17
II		21	22	23	24	25		26	27
III		31	32	33	34	35		36	37

Fig. 13. Wiring diagram of the KR5A recorder

7. PUTTING THE RECORDER INTO OPERATION

7.1. Removing from the housing

- open the recorder door,
- take the protection wedges (33) out from each side of the winding assembly,

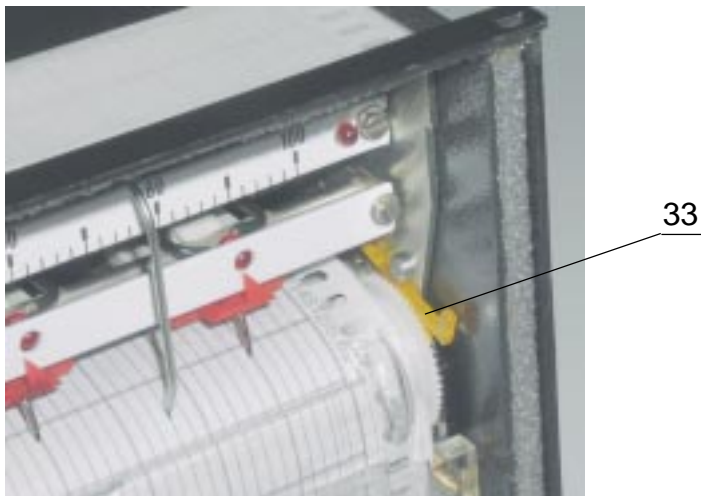

Fig. 14.

- pulling by the projection (45) in the winding assembly in the upper part of the guide (37), deflect it to the vertical position,

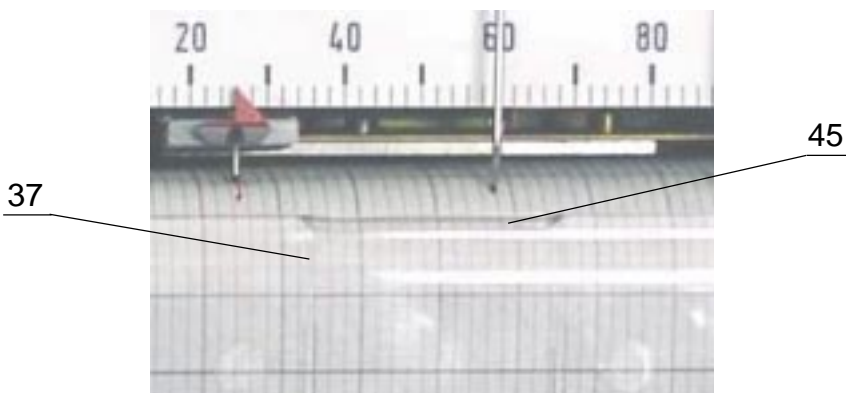

Fig. 15.

- pulling by the guide take the winding assembly out from the recorder,

- remove the edge (34) securing the recorder inside the housing during the transport,

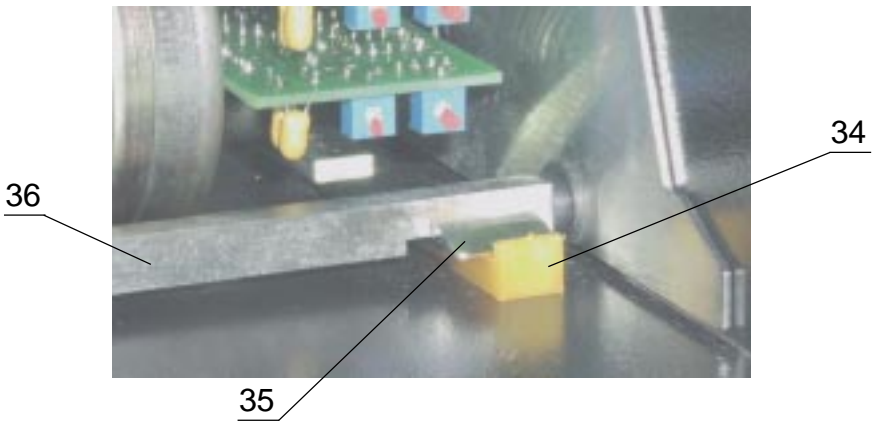

Fig. 16.

- press the catch (35) down and take the recorder out from the ho using by the spacer (36)

7.2. Preparation to work



- insert the recorder into the housing till the snap fastener operation,
- switch the supply on,
- set the required chart tape feed
- insert the appropriate pens into the carriage grips,
- tighten the chart tape (see the point 8.1.),
- insert the winding assembly into the recorder,
- shut the door.

8. RECORDER SERVICING

8.1. Recorder chart replacement

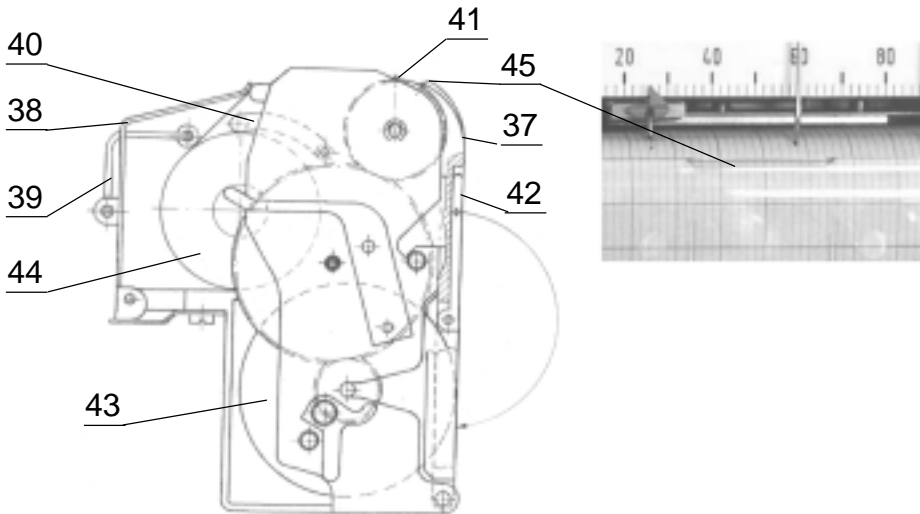

Fig. 17.

When replacing the Z-fold recording chart one must:



- pull by the projection /45 / in the upper part of the guide /37/, and deflect it to the horizontal position,
- pulling by the guide, take the chart rewriter out from the recorder,
- take the recorded chart out from the cassette,
- deflect the cover /38/ with the lever /39/,
- insert a new chart into the cassette, under the bow /40/, pull out ca 100 mm of the chart and close the cover /38/,
- place the chart with its perforations on the wheel dogs /41/, and close the guide /37/,
- tighten the chart turning the wheel with dogs (41),
- paper guides /42/ should be turned in the lower position and snapped as it is shown by the arrow,
- insert the chart rewriter into the recorder

When replacing the roll recording chart one must:



- pull by the projection /45 / in the upper part of the guide /37/, and deflect it to the horizontal position,
- pulling by the guide, take the chart rewriter out from the recorder,
- take the coiling roll /43/ out with the recorded chart,
- take the flange /metallic/ out from the coiling roll /43/,
- holding the recording chart, make several turns with the second flange in the opposite direction to the chart winding direction,
- pull the chart off from the coiling roll /43/,
- deflect the cover /38/ with the lever /39/,
- insert a new chart /44/ into the cassette, under the bow /40/, pull out ca 150 mm of the chart and close the cover /38/,
- insert the chart end into the slot of the coiling roll and wind 2...3 coils,
- place the chart with its perforations on the wheel dogs /41/ and insert the coiling roll into the cassette with its pins into the slots of the lateral plates of the chart rewriter and close the guide /37/,
- tighten the chart turning the wheel with dogs (41),
- paper guides /42/ should be positioned in the upper position and snapped, as shown on the design,
- insert the chart rewriter into the recorder.

8.2. Pen replacement

We use three kinds of pens in the recorder, differing in line colour, and tube dimensions according the measuring channel number.

The decay or visible atrophy of recording attests that the ink reserve in the fount is run out. In this case, one should exchange the pen for a new one. For this, one should:

- size the tube between two fingers, near the fount and take the pen out from the carriage holder,
- insert a new pen into the carriage holder till the snap fastener operation.

1. **red** - **F51614A-02X**
(channel 1 or event markers)
2. **blue** - **F51615A-03X**
(channel 2)
3. **green** - **F51616A-04X**
(channel 3)

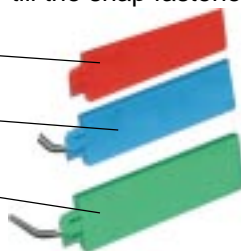

Fig. 18.

8.3 Lubrication



For lubrication, one must use Renolin MR30 oil (FUCHS Company) or similar, which is included in the accessory set of the recorder.

Every ca 3 months of the recorder exploitation, remove the collected impurities on the carriage guide /46/. Drift on the carriage guide a small quantity of oil (2 drops) and distribute it by several displacements of the carriage and then, wipe the guide to a dry state. Every 6 months of the recorder exploitation, lubricate with a small quantity of oil the friction faces in the drive chart gear (marked by **S** on the fig.19).

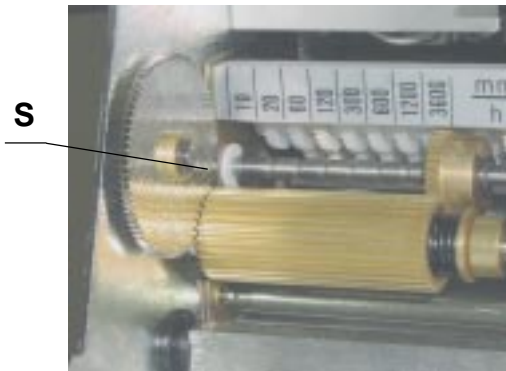

Fig. 19.

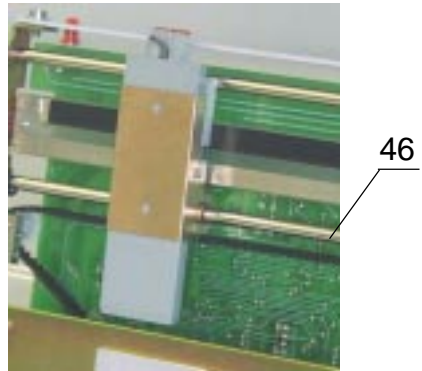

Fig. 20.

8.4. Recorder control

8.4.1. Alarm control

In order to set the point of alarm operation for „**MIN**” or „**MAX**”, one must take the short circuiting nipple (47) out from the **WORK** joint and insert it into the **REG.MIN** (48) or **REG.MAX** (49) joint. Set the pen position by means of the potentiometer knob of the **MIN** (50) or **MAX** (51) control on the scale point in which the alarm operation will be to occur.

Next, insert the short circuiting nipple (47) in the **WORK** joint again.

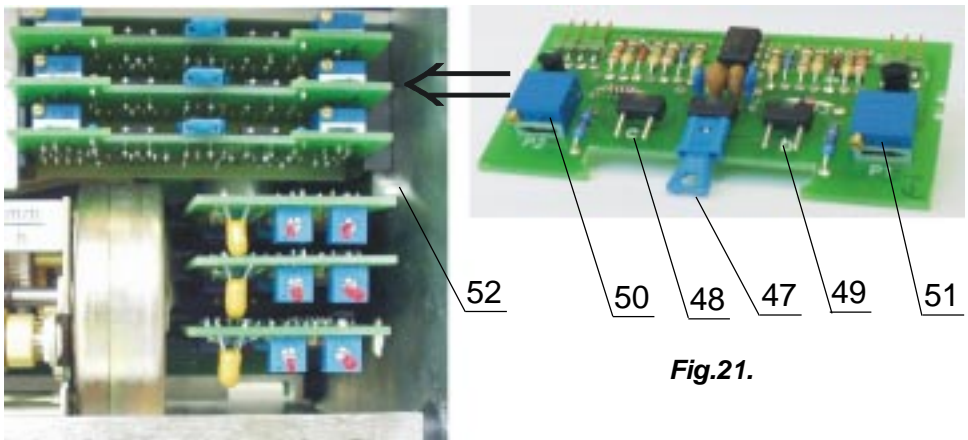

Fig.21.

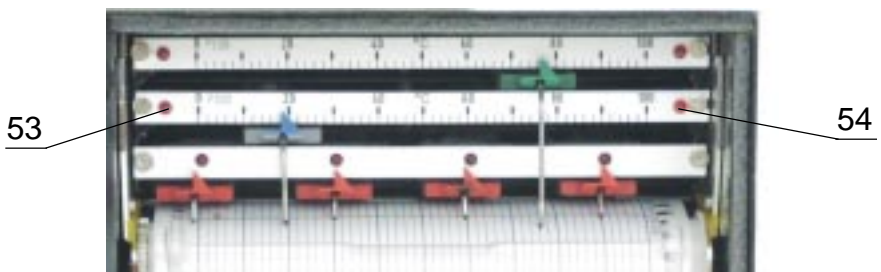

Fig.22.

After the transmission of a signal on the recorder input with a value producing the exceeding of set operation points of the alarm system, at the pen movement to the right for **MAX** and to the left for **MIN**, follows the lighting of the alarm diode **MIN** (53) or **MAX** (54) and the short circuiting or opening of alarm relay contacts led out on the terminal plate. To take the alarm plate out from the recorder, one must displace the block lever (52) into its lower position.

8.4.2. Calibration of the measuring channel

This is a procedure carried out by the recorder manufacturer consisting on:

- sensitivity control of the measuring system (the pen is to react against each increment of the input signal corresponding to 0,25% of the measuring range without oscillations),
- control of the pen position on 0% and 100% lines of the recording tape and in such a position that the initial and final line of the scale will cover with the pen index,
- control of the pen exit beyond the 0% and 100% description lines of the tape (this exit is set at less than 1.5 mm).
- After the calibration of one of the channel, the control of the others is made in such a way that the character of the crossing, dumping and exit in all channels were similar.

When using recording tape from a new delivery, it is recommended to carry out the coincidence checking of the beginning and end of the measuring range accordingly to the 0% and 100% description lines of the recording tape and make the above calibration if the divergence exceeds 0.2 mm.

8.4.3. Correction of the sensitivity of the measuring system

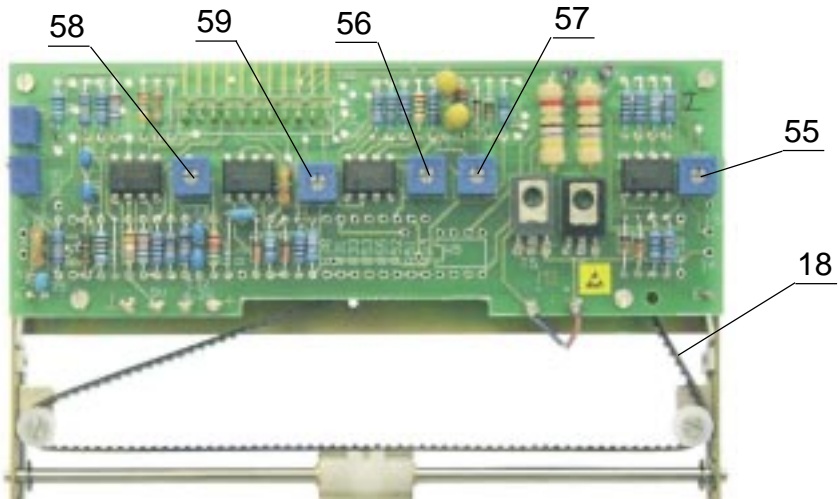

Fig.23.

Apply on the recorder input a signal corresponding to the upper limit of the measuring range.

Change the amplification in the potentiometer amplifier system (55), from the oscillation state of the carriage till their cessation.

Check the sensitivity of the system.

The pen should react against each increment of the input signal corresponding to 0.25% of the measuring range.

If we cannot obtain the appropriate sensitivity without the occurrence of oscillations, one must correct the pull of the toothed strip (18).

Through the change of the strip pull one can also adjust the fluidity of the carriage displacement.

8.4.4. Correction of the pen adjustment

- ***Measuring channel without the range insert***

Apply a signal corresponding to the upper limit of the measuring range on the measuring input.

By means of the potentiometer (56), in the amplifier system, set the carriage such a way that the pen was set on the line of the recording tape corresponding to the input signal. The initial line of the scale must cover the pen index.

By means of the potentiometer (57), in the amplifier system, set the carriage such a way that the pen was set on the line of the recording tape corresponding to the input signal. The end line of the scale must cover the pen index.

- ***Measuring channel with the range insert***

If during the recorder operation the necessity occurs to change the pen position in relation to the recording tape and the dial, the correction must be carried out by means of potentiometers of the range insert (60) and (61).

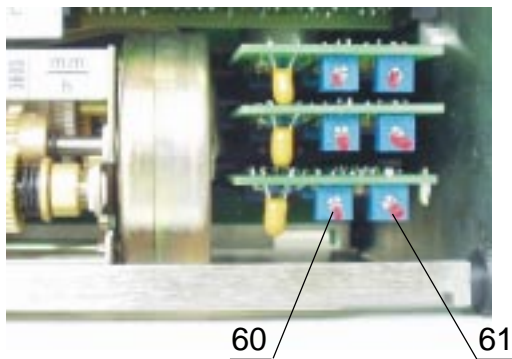

Fig.24.

8.4.5. Control of the pen exit

By means of the potentiometers (58) and (59), in the amplifier system, one can control the pen exit accordingly: to the left - from the initial description line of the tape recording, and to the right - from the final description line of the recording tape.

This exit should be set at less than 1.5 mm.



Fig.25.

Note: Measuring assemblies can be taken out of the recorder frame after unskrewing of the blocking screw (62)

9. TECHNICAL DATA

Bezel recorder dimensions	144 x 144 mm
Recording width	100 mm
Measuring range:	0...1 mA to 100 mA 0...5 mV to 100 mV
Fe-CuNi	0...100°C to 900°C
NiCr-NiAl	0...150°C to 1300°C
PtRh10-Pt	0...1200°C to 1760°C
PtRh30-Pt	0...1200°C to 1800°C
Pt100 /1.3850	od 30°C to +850°C
Ni100 /1.617	od 50°C to +150°C
- with thermocouple	corresponding to $\Delta U \geq 5$ mV
- with resistance thermometer	corresponding to $\Delta R \geq 20 \Omega$
Additional error for linearized scales	$\leq 0,5\%$
Quantity of measuring channels	1, 2 or 3 (as per order)
Length behind pannel	284 mm
Accuracy class	0,5
Tape feed speed	10, 20, 60, 120, 300, 600, 1200, 3600 mm/h or 5, 10, 20, 60, 120, 300, 600 mm/h
Response time	$\leq 1,5$ s
Measuring system	Poggendorf's potentiometric system
Recording time accuracy	$\leq 0,5\%$
Ambient temperature range	0...50°C
Recording	pen adapted for a 1000 meter running
- channel 1 (lower):	red
- channel 2 (middle)	blue
- channel 3 (upper)	green
Signalling system	2 per channel
Dead signal zone	$\leq 0.5\%$
Setting range for signalling operation threshold	0...100% of the measuring range

Contact loading	0,5 A, 250 V (60 W, 125 VA)
Retransmission signals	0...5 V/1 mA or 0...20 mA/400 Ω
Event marker supply	12 V d.c., 0.1 A for 1 event marker
Voltage supply	207... <u>230</u> ...253 V a.c.
Voltage supply frequency	45... <u>50</u> ...65 Hz
Working position	vertical ± 10°
Protection degree ensured:	
- by the housing	IP65, acc. DIN 40050
- by terminals	IP00, acc. DIN 40050
Power consumption	≤ 6 VA per channel
Recording tape	Recording paper 16 m long. Roll tape or Z-fold tape acc. DIN 16230

ELECTROMAGNETIC COMPATIBILITY:

Service security

- requirements and testing
acc. IEC1010-1

I protection class

Perturbance immunity:

- requirements and testing
- additional error

EN50082-2

≤ 1%

Level of radioelectric perturbances

class A, acc. EN55011

MEASURING RANGES

Table 1

Range No	Range	Typ of sensor
01	0...1	mA
02	0...5	
03	0...20	
04	0...50	
05	0...100	
06	5...0...5	
07	20...0...20	
08	50...0...50	
09	100...0...100	
10	4...20	
11	0...5	mV
12	0...10	
13	0...15	
14	0...25	
15	0...40	
16	0...60	
17	0...100	
18	5...0...5	
19	10...0...10	
20	20...0...20	
21	50...0...50	
22	0...5	V
23	0...10	
24	5...0...5	
25	10...0...10	
26	0...100°C	Fe-CuNi with automatic cold junction temperature compensation
27	0...150°C	
28	0...250°C	
29	0...400°C	
30	0...600°C	
31	0...900°C	
32	0...100°C	Fe-CuNi cold junction reference temperature +50°C
33	0...150°C	
34	0...250°C	
35	0...400°C	
36	0...600°C	
37	0...900°C	
38	0...150°C	NiCr-NiAl with automatic cold junction temperature compensation
39	0...250°C	
40	0...400°C	
41	0...600°C	
42	0...900°C	
43	0...1300°C	
44	400...900°C	

- 1) Execution without linearization.
- 2) As a standard, the recorder is adapted to the 4-wire connection of the resistance thermometer. A two-wire connection is also possible after agreement.

Table 1 (continuation)

Range No	Range	Typ of sensor
45	0...150°C	
46	0...250°C	
47	0...400°C	NiCr-NiAl
48	0...600°C	cold junction
49	0...900°C	reference
50	0...1300°C	temperature +50°C
51	400...900°C	
52	0...1200°C	PtRh10
53	0...1600°C	with automatic
54	400...900°C	cold junction
55	800...1400°C	temperature
56	1000...1600°C	compensation
57	1200...1760°C	
58	0...1200°C	
59	0...1600°C	PtRh10-Pt
60	400...900°C	cold junction
61	800...1400°C	reference
62	1000...1600°C	temperature +50°C
63	1200...1760°C	
64 ¹⁾	0...1200°C	PtRh30-PtRh6
65 ¹⁾	0...1600°C	without automatic
66	800...1400°C	cold junction
67	1000...1600°C	temperature
68	1200...1800°C	compensation
69	30...60°C	
70		
71		
72	0...60°C	
73	0...100°C	
74	0...150°C	
75	0...250°C	
76	0...400°C	Pt100 /1,3850 ²⁾
77	0...600°C	
78	100...200°C	
79	200...400°C	
80	300...600°C	
81	50...100°C	
82	50...100°C	
83	30...60°C	
84	20...20°C	
85	0...40°C	Ni100 /1,617 ²⁾
86	0...60°C	
87	0...100°C	
88	0...150°C	
89		
99		Non-catalogue range

1) Execution without linearization.

2) As a standard, the recorder is adapted to the 4-wire connection of the resistance thermometer. A two-wire connection is also possible after agreement.

10. EXECUTIONS CODES AND ORDERING

Table 2

THREE-CHANNEL PEN RECORDER - KR5A		XX	XX	XX	X	X	X	X	X
I channel range number (lower pen)¹⁾									
Measuring range (instead of XX , write a two digit range, as per table 1)	XX								
Non-catalogue range	99								
Execution with event markers	00								
II channel range number (middle pen)									
Measuring range (instead of XX , write a 2-digit range as per table 1)	XX								
non-catalogue range	99								
III channel range number (upper pen)									
Measuring range (instead of XX , write a 2- digit range as per table 1)	XX								
non-catalogue range	99								
Alarms: (two for each channel)									
Execution without alarms								0	
Execution with normally short-circuiting contact relays								1	
Execution with normally open contact relays								2	
Retransmission signals:									
Without a retransmission signal								0	
With a retransmission signal 0...20 mA ²⁾								1	
With a retransmission signal 0...5 V ²⁾								2	
Event markers:									
Execution without event markers								0	
Execution with 2 event markers ³⁾								1	
Execution with 4 event markers ³⁾								2	
Scale description:									
Execution conform to a catalogue range. Linearized scale ⁴⁾									1
Execution conform to a catalogue range. Drawn scale									2
Execution with description 0...100%									3
Execution with blank scale									4
Custom-made execution of the scale									9
Acceptance tests:									
Without a quality inspection certificate									0
With an extra quality inspection certificate									1
According user's agreement ⁵⁾									X

1) The lower pen is not assembled in the channel I for an execution with an event marker.

2) For KR5A without alarms.

3) For two channel KR5A recorders.

4) Concerns temperature ranges.

5) The manufacturer establishes the code number.

EXAMPLE OF ORDER KR5A 00 40 76 1 0 2 1 0 means

The execution of a KR5A recorder with:

00 - event markers in the channel I,

40 - measuring range: 0...400 °C NiCr-NiAl with ACJC, in the channel II,

76 - measuring range: 0...400 °C Pt100/1.3850 in the channel III,

1 - with 2 alarms and normally short-circuiting contact relays per channel,

0 - with a retransmission signal,

2 - with 4 event markers,

1 - with a linearized scale conform with the catalogue range,

0 - without a quality inspection certificate.

11. MAINTENANCE AND GUARANTEE

The KR5A recorder requires some periodical maintenance as described in the Service Manual.

In case of some incorrect unit operations:

1. From the shipping date, during the period given in the annexed guarantee card :

One should take the instrument down from the installation and return it to the Manufacturer's Quality Control Dept.

The disassembling of the housing causes the cancellation of the granted guarantee.

2. After the guarantee period:

One should turn over the recorder to repair it in a certified service workshop. Spare parts are available for the period of ten years from the date of purchase.



The Manufacturer's reserves the right to make changes in design and specifications of any products as engineering advances or necessity requires.

APRIL 2004