



Type-5500 Multi-station Digital to Pneumatic Pressure Regulator with DeviceNet

Technical Manual



Table of Contents

Type-5500 Introduction.....	3
Product Overview	3
About DeviceNet.....	4
Overview	4
Type-5500 DeviceNet Features	4
Cabling and Drop Line Lengths (as defined by DeviceNet specification)	4
Maximum Main Trunk Cable Length.....	4
Drop Line Cable Length.....	4
Type-5500.....	5
Removable Miniature Electropneumatic Regulators	5
Calibrating Miniature Electropneumatic Regulators	6
Type-550 Regulator.....	6
Type-900 Regulator.....	7
Module Configurations and Pinouts	8
Factory Default Settings	8
LED Display	8
Connector Types.....	8
DeviceNet Communication Connector Pin Out	9
Auxiliary Power Connector Pin Out.....	9
Power Supply Wiring Diagrams	10
Single Power Supply Example (Male connector view).....	10
Separate Power Supply Example (Male connector view).....	10
Power Consumption	11
Auxiliary Power Connector – Power Pins	11
Power Ratings.....	11
Recommended External Fuses:	11
Power Consumption and External Fuse Sizing Guide	12
MAC ID and Baud Rate Configuration	13
Rotary Switch Settings (SW1 & SW2).....	13
DIP Switch Settings (SW3) Continued.....	14
Settings Example	14
DeviceNet Configuration and Mapping.....	15
EDS File.....	15
I/O Message Types.....	15
I/O Setup.....	15
Manifold I/O Sizing Table	10
Bit Mapping Rules.....	17
I/O (Rx/Tx) Sizes.....	17
Rx/Tx Size Calculation Errors.....	17
I/O Mapping.....	18
Example #1 I/O Table.....	19
Diagnostics	21
LED Functions	21
Appendix.....	22
System Specifications	22
Factory Default Settings	22
Troubleshooting	23
Technical Support	26

Type-5500 Introduction

Product Overview

The Type-5500 is a manifold proportional control regulator that utilizes one fieldbus node to control up to eight miniature electropneumatic regulators, which eliminates multiple nodes and costly wiring. Optional feedback provides an additional input to the PLC indicating the output pressure of each regulator.

The ControlAir T-5500 DeviceNet node is designed to DeviceNet specification, release 2.0 and supports the following I/O Message types: Polled, Change of State (COS), Cyclic and Combinations (i.e. Outputs can be set for Polled while Inputs can be set for COS for improved system response time).

This manual addresses the specifics of configuring and commissioning the ControlAir Type-5500 product configured with the DeviceNet communication interface.

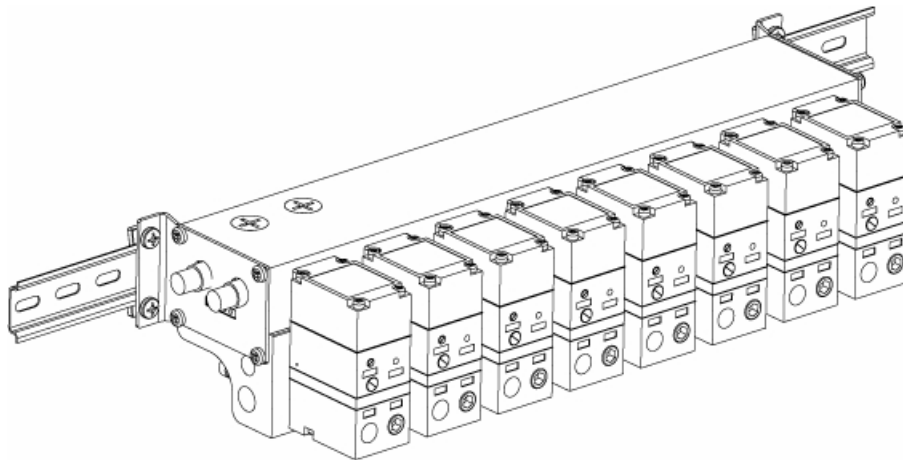

About DeviceNet

Overview

DeviceNet is a bus communication protocol used to network industrial devices to eliminate labor intensive and expensive point to point wiring schemes. It is based on the CAN (Controller Area Network) protocol. Allen Bradley originally developed DeviceNet, but it is now supported by a multitude of manufacturers.

The ODVA (Open DeviceNet Vendor Association) is an independent organization that governs the DeviceNet specification and oversees conformance testing for products, which will be used in a DeviceNet system.

DeviceNet uses a powered 4-wire network and can have up to 64 nodes. The protocol can transfer a maximum of 8 bytes of data per node cycle with three selectable communication (baud) rates; 125 Kbps, 250 Kbps, or 500 Kbps. Maximum trunk cable distance depends upon baud rate and cable media type. Refer to the table below for details.

More information about DeviceNet and ODVA can be obtained from the ODVA web site <http://www.odva.org>

MPCR DeviceNet Features

<i>Features</i>	<i>Description</i>
DeviceNet Spec. Supported	Designed to DeviceNet Specification Revision 2.0
Bus Topology	Straight with restricted drops
Baud Rates Supported	125Kbps, 250 Kbps and 500 Kbps and Autobaud
Duplicate address detection	If a duplicate address is detected on power up, duplicates will not progress to run mode
Error Correction	Yes, if an error is detected, sender is requested to repeat the message
Address Setting	Done by internal switches
Termination Resistor (external)	A 121 ohm, 1%, ¼ Watt resistor is required at each end of the trunk line
I/O Message Types Supported	Polled, Cyclic, Change of State (COS) or Combinations

Cabling and Drop Line Lengths (as defined by DeviceNet specification)

Maximum Main Trunk Cable Length

Baud Rate	Thick Trunk Cable	Thin Trunk Cable	Flat Trunk Cable
125 Kbps	1640 ft (500 m)	328 ft (100 m)	1246 ft (380 m)
250 Kbps	820 ft (250 m)	328 ft (100 m)	656 ft (200 m)
500 Kbps	328 ft (100 m)	328 ft (100 m)	246 ft (75 m)

Drop Line Cable Length

Baud Rate	Maximum Drop Length	Cumulative Drop Length
125 Kbps	20 ft (6 m)	512 ft (156 m)
250 Kbps	20 ft (6 m)	256 ft (78 m)
500 Kbps	20 ft (6 m)	128 ft (39 m)

Type-5500

Removable Miniature Electropneumatic Regulators

The Type-5500 uses individual shutoffs on each station, which allows the users to service regulators while the rest of the manifold remains functional. This is possible due to the backplane electronics.

The steps involved to remove the miniature electropneumatic regulators are as follows:

1. Rotate inner valve to shutoff air supply to individual regulator.
2. Turn large 11/16th Hex to remove regulator.
3. Lift orange spring clips to remove wires from the backplane circuit board.

Reverse steps in order to install regulators. When connecting regulators to the backplane circuit board, be aware that the red wire from the regulator must be inserted on the left and the black wire must be inserted on the right while facing the front of the manifold.

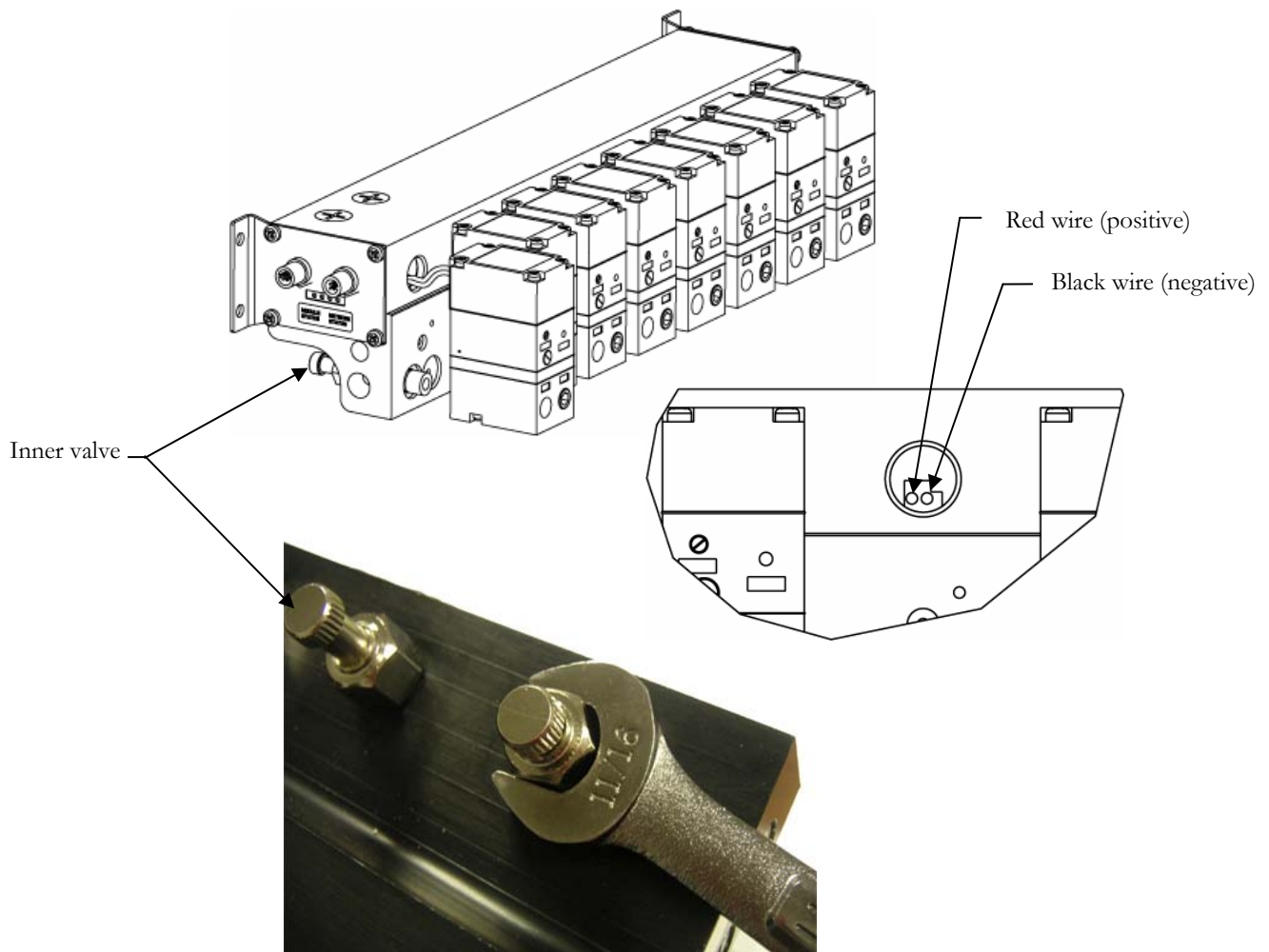

Calibrating Miniature Electropneumatic Regulators

Type-550 Regulator

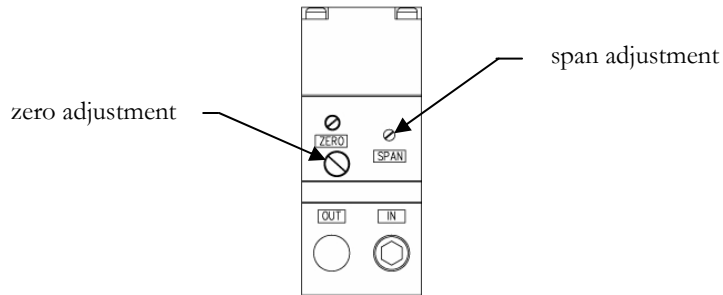

Calibration

All units are shipped from the factory calibrated, it is suggested that the user check the calibration once the manifold is installed.

The unit is calibrated so that minimum input signal corresponds to minimum output pressure and increasing input signal results in increase output pressure, where maximum input signal results in maximum output pressure.

1. Apply the minimum input signal from the controller.
2. Observe the output pressure. If necessary, adjust the zero screw until reaching the minimum output pressure setting. Turn zero screw clockwise to increase and counter-clockwise to decrease.
3. Apply the maximum input signal from the controller.
4. Observe the output pressure. If necessary, adjust the span screw until reaching maximum output pressure setting. Turn span screw clockwise to increase and counter-clockwise to decrease.
5. After setting the span it will be necessary to recheck the zero. Repeat steps 1-4 until both end points are at required values.

Type-900 Regulator

Calibration

All units are shipped from the factory calibrated, it is suggested that the user check the calibration once the manifold is installed.

The unit is calibrated so that minimum input signal corresponds to minimum output pressure and increasing input signal results in increase output pressure, where maximum input signal results in maximum output pressure.

1. Apply the minimum input signal from the controller.
2. Observe the output pressure. If necessary, adjust the zero screw until reaching the minimum output pressure setting. Turn zero screw clockwise to decrease and counter-clockwise to increase.
3. Apply the maximum input signal from the controller.
4. Observe the output pressure. If necessary, adjust the span screw until reaching maximum output pressure setting. Turn span screw clockwise to decrease and counter-clockwise to increase.
5. After setting the span it will be necessary to recheck the zero. Repeat steps 1-4 until both end points are at required values.

Module Configurations and Pinouts

Factory Default Settings

Type	Value	Description
Baud Rate	Autobaud	Autobaud enabled (automatically detects 125Kbps, 250Kbps and 500Kbps)
Node Address	63	MAC ID value
Rx/Tx	Various	The produced (Tx) and consumed (Rx) values of the manifold system. The total number of I/O that the manifold is configured for. (See <u>Configuration and Mapping</u> for additional information on page 14)
I/O Message Type	Polled	Communication connection

LED Display

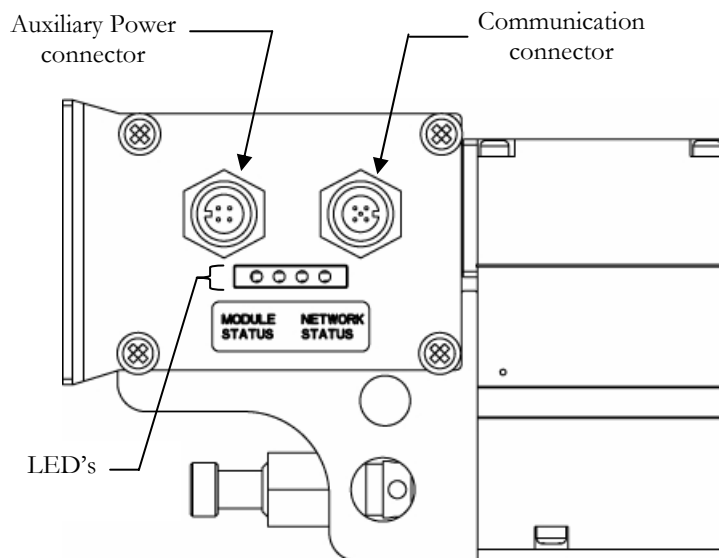

Connector Types

Industry standard 12mm, micro connectors are used for communication and auxiliary power. The DeviceNet communication connector is a single keyway 5-pin male connector while the Aux. Power connector is a single keyway 4-pin male connector.

DeviceNet Communication Connector Pin Out

Pin #	Function	Description
1	Drain	Drain or shield
2	V+	Bus Power, 11-25VDC
3	V-	Bus Power, Common
4	CAN_H	Controller Area Network High, Communication Line
5	CAN_L	Controller Area Network Low, Communication Line

Auxiliary Power Connector Pin Out

Pin #	Function	Description
1	+24VDC (Valves)	Voltage Used to Power Valves
2	Earth Ground	Protective Earth
3	0VDC Common	0VDC Common, for Valve and I/O Power
4	+24VDC (Node and Discrete I/O)	Voltage Used to Power Discrete I/O and Node Electronics

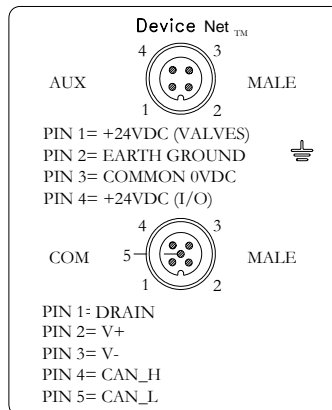

- *Maximum pin capacity on pin #3 (0VDC common) of auxiliary power connector is 4 Amps. The combined draw of Pin #1 (Valves) and pin #4 (I/O) cannot exceed 4 Amps, at any given moment in time.*
- *Auxiliary power connector Pin #4 supplies power to node electronics. This pin must be powered at all times for communication node to be functional*

Electrical Connections

Power Supply Wiring Diagrams

Single Power Supply Example (Male connector view)

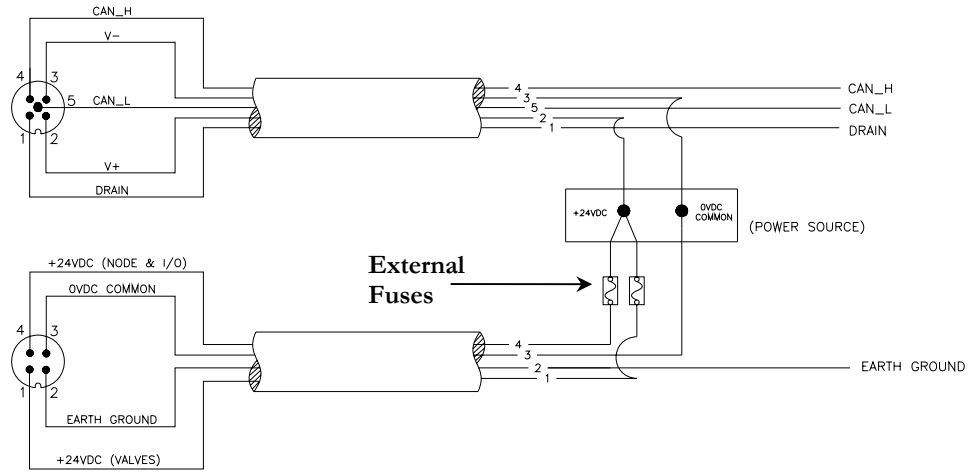

Separate Power Supply Example (Male connector view)

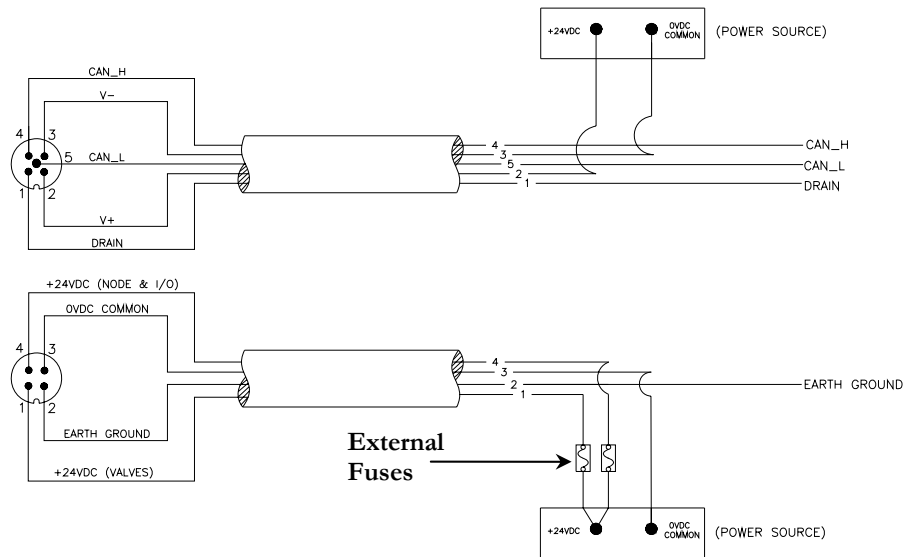

- *Please see page 12 for external fuse sizing guide.*
- *When using molded connector power cables, **Do Not** rely on wire colors for Pin-Out. Always use pin number references.*

Power Consumption

Auxiliary Power Connector – Power Pins

Aux. Power Connector Pin #	Description
1	Powers Outputs (Valves)
4	Powers Discrete I/O and Node Electronics

Power Ratings

- Maximum system current capability is **4 amps**. Care should be taken not to exceed 4 amp draw through pin #3, 0VDC common (pin #1 and pin #4 combined).

<i>Auxiliary Power Connector</i>	<i>Volts</i>	<i>Tolerances</i>	<i>Current</i>	<i>Power</i>
<i>Pin 1 +24VDC (Valves)</i>				
Type-550 Regulator (Each)	24VDC	+10%/-15%	0.020 A	0.50 Watts
Type-900 Regulator (Each)	24VDC	+10%/-15%	0.020 A	0.50 Watts
<i>Pin 4 +24VDC (Node & I/O)</i>				
Node	24VDC	+/- 10%	0.015 A	0.36 Watts
<i>Communication Connector</i>	<i>Volts</i>	<i>Tolerances</i>	<i>Current</i>	<i>Power</i>
Pins 2 & 3 Bus Power (V+ and V-)	24VDC	11-25 VDC	0.025 A	0.6 Watts

Recommended External Fuses:

External fuses should be chosen based upon the physical manifold configuration. Please refer to the following page for the fuse sizing guide.

Power Consumption and External Fuse Sizing Guide

Power Consumption - Aux. Power Connector Pin #1 – (Regulators)	
<i>Description</i>	<i>Current</i>
Number of Type-550 Regulators ___ X 0.020 A =	_____ Amps
	+
Number of Type-900 Regulators ___ X 0.020 A =	_____ Amps
Total Regulator Current*:	_____ Amps
Surge Compensation: X	1.25
Suggested External Pin #1 Fuse Value:	_____ Amps

Power Consumption - Aux. Power Connector Pin #4 – (Node)	
<i>Description</i>	<i>Current</i>
Communication Node Power Consumption =	0.070 Amps
Surge Compensation: X	1.25
Suggested External Pin #4 Fuse Value:	0.250 Amps

*The combination of total regulator current must not exceed 4 Amperes.



At any given moment in time, the combined current draw through pin #1 (Regulators) and pin #4 (Node) cannot exceed 4 amperes. Therefore, the combined value of the two fuses on pin #1 and pin #4 should not exceed 5 amperes (4 amperes max by 1.25 surge compensation).

MAC ID and Baud Rate Configuration

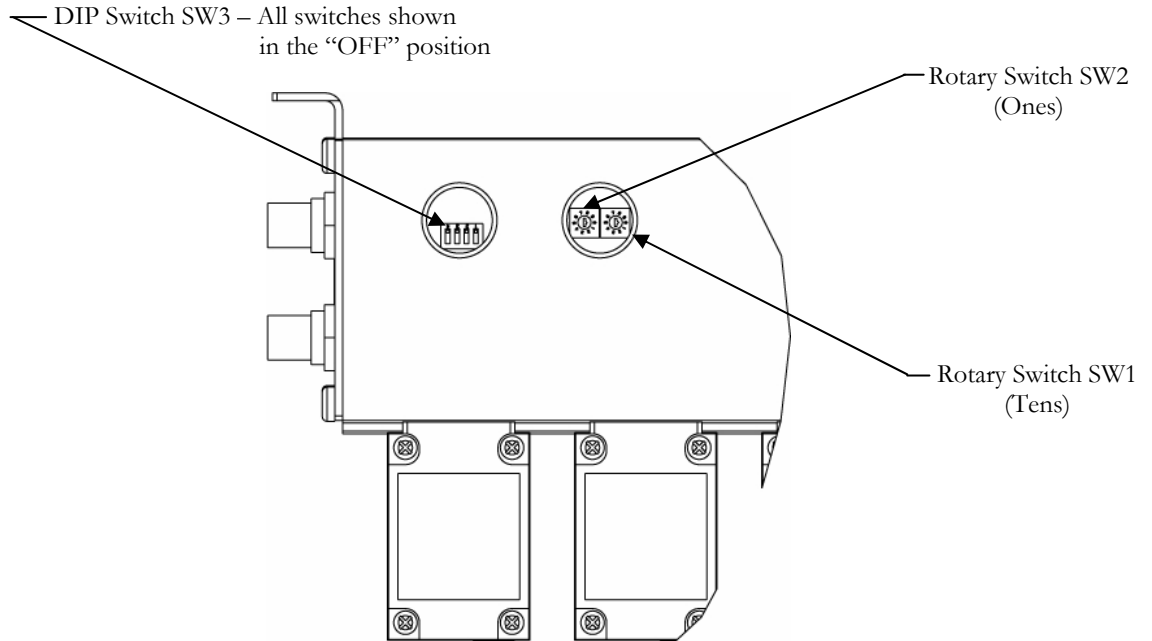

DIP and rotary switch settings do not take effect until power is cycled (turned OFF and ON).

Rotary Switch Settings (SW1 & SW2)

MAC ID (Network Address):

Switch	Description
SW1	Sets the Tens Digit (MSD)
SW2	Sets the Ones Digit (LSD)



- *Address is set to a default setting of 63 prior to shipment. Rotary switch settings over 63, default to 63.*
- *Node address may only be assigned once per scanner card.*
- *EDS files may be downloaded from our web site at www.numatics.com*

DIP Switch Settings (SW3) Continued

Baud Rate:

SW3-1	SW3-2	Kbaud
Off	Off	125
Off	On	250
On	Off	500
*On	*On	Autobaud

Reserved:

Switch	Description
SW3-3,4	Not Used – Reserved for future use

* Factory Default Settings

Settings Example

The example below shows the correct settings for the following requirements:

Baud Rate = 500 Kbaud;
Address = 23

Switch Settings:

Switch	Setting	Description
SW1	2	Sets the Tens Digit of MAC ID to Two (2)
SW2	3	Sets the Ones Digit of MAC ID to Three (3)
SW3-1 SW3-2	On Off	Sets Baud Rate to 500 Kbps

DeviceNet Configuration and Mapping

EDS File

The EDS file contains configuration information required to establish communication to a node on a DeviceNet network. An EDS stub file is loaded into the communication node prior to shipment and can be uploaded from the node with appropriate DeviceNet software (i.e. DeviceNet Manager, RS NetWorx, etc...). There is an EDS file available for download, please contact ControlAir technical support for more information.

I/O Message Types

The ControlAir Type-5500 DeviceNet communication node supports 3 different I/O message types. Below are brief definitions for the supported types:

Polled

The poll command is an I/O message that is transmitted by the Master. A Poll Command is directed towards a single, specific Slave (point to point). A Master must transmit a separate Poll Command Message for each one of its Slaves that is to be polled. The slave can respond with an I/O Message that is transmitted back to the Master.

Cyclic

The Cyclic message is transmitted by either the Master or the Slave. An Acknowledge Message may be returned in response to this message. The message is sent based on the value of a cyclic timer, which is set by the user.

Change of State

The Change of State message is transmitted by either the Master or the Slave. An Acknowledge Message may be returned in response to this message. The message is sent whenever a change of state occurs (i.e. an input changes from "On" to "Off").

I/O Setup

Outputs (Tx)

Outputs are defined as any miniature electropneumatic regulator. The output byte size (Tx) depends upon the physical configuration of the manifold. Please reference the following pages for the output byte size (Tx).

Inputs (Rx)

The inputs are only applicable if the manifold has a feedback option. The input byte size (Rx) depends upon the physical configuration of the manifold. Please reference the following pages for the input byte size (Rx).

Manifold I/O Sizing Table

Part No.	Description	Rx (Input Bytes)	Tx (Output Bytes)
5500-B_F	4 Station DeviceNet Manifold with Feedback Option	4	4
5500-B__	4 Station DeviceNet Manifold	4	0
5500-C_F	4 Station DeviceNet Manifold with Feedback Option	6	6
5500-C__	4 Station DeviceNet Manifold	6	0
5500-D_F	4 Station Profibus Manifold with Feedback Option	8	8
5500-D__	4 Station Profibus Manifold	8	0

Bit Mapping Rules

Bit mapping for the Type 5500 varies with the physical configuration of the manifold. The following is a breakdown of the bit mapping rules associated with the Type 5500 manifold.

Regulators

Outputs (Tx)

1. The number of output bytes corresponds directly to the number of stations on the manifold assembly. One byte for every station on the manifold.

Inputs (Rx)

1. Input bits are on dependent on the manifold configuration.
2. If the feedback manifold is selected, then the number of output bytes corresponds to the number of stations on the manifold assembly. Two bytes for every station.

I/O (Rx/Tx) Sizes

Rx/Tx Size Calculation Errors

When the required manifold Input/Output (Rx/Tx) byte sizes are incorrectly set in the Allen-Bradley DeviceNet Configuration Software (i.e. RS Networx, DeviceNet Manager, etc.), the A-B DeviceNet scanner will error. The expected error code for this situation will be *Error 77 – “Data Size Return Does Not Match Entry”*.

Review your Rx/Tx size calculation to be sure they match the physical configuration of the manifold.

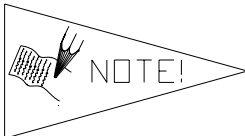

Although the Rx/Tx values must be declared in the DeviceNet software for proper operation, they do not have to be mapped in the scanner.

I/O Mapping

Example
5500-DCF

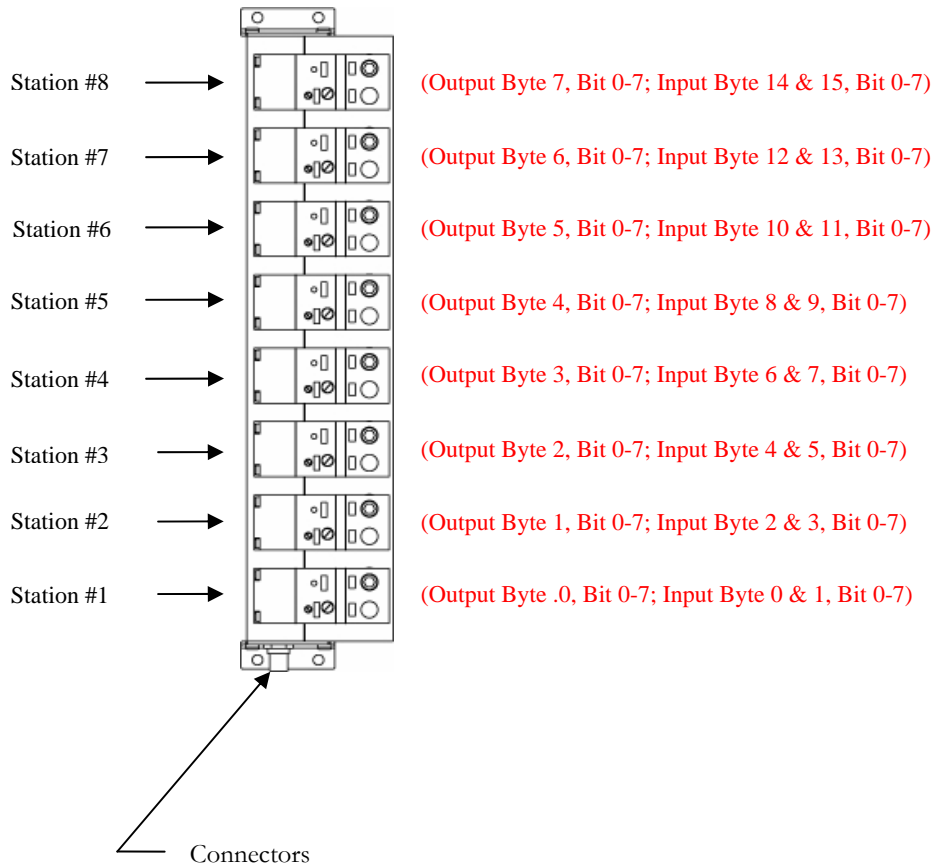

Example #1 I/O Table

Output Table								
BYTE	Bit 7	Bit 6	Bit 5	Bit 4	Bit 3	Bit 2	Bit 1	Bit 0
0	Regulator #1	Regulator #1	Regulator #1	Regulator #1	Regulator #1	Regulator #1	Regulator #1	Regulator #1
1	Regulator #2	Regulator #2	Regulator #2	Regulator #2	Regulator #2	Regulator #2	Regulator #2	Regulator #2
2	Regulator #3	Regulator #3	Regulator #3	Regulator #3	Regulator #3	Regulator #3	Regulator #3	Regulator #3
3	Regulator #4	Regulator #4	Regulator #4	Regulator #4	Regulator #4	Regulator #4	Regulator #4	Regulator #4
4	Regulator #5	Regulator #5	Regulator #5	Regulator #5	Regulator #5	Regulator #5	Regulator #5	Regulator #5
5	Regulator #6	Regulator #6	Regulator #6	Regulator #6	Regulator #6	Regulator #6	Regulator #6	Regulator #6
6	Regulator #7	Regulator #7	Regulator #7	Regulator #7	Regulator #7	Regulator #7	Regulator #7	Regulator #7
7	Regulator #8	Regulator #8	Regulator #8	Regulator #8	Regulator #8	Regulator #8	Regulator #8	Regulator #8

Input Table *								
BYTE	Bit 7	Bit 6	Bit 5	Bit 4	Bit 3	Bit 2	Bit 1	Bit 0
0	Station #1 Input	Station #1 Input	Station #1 Input	Station #1 Input	Station #1 Input	Station #1 Input	Station #1 Input	Station #1 Input
1	Station #1 Input	Station #1 Input	Station #1 Input	Station #1 Input	Station #1 Input	Station #1 Input	Station #1 Input	Station #1 Input
2	Station #2 Input	Station #2 Input	Station #2 Input	Station #2 Input	Station #2 Input	Station #2 Input	Station #2 Input	Station #2 Input
3	Station #2 Input	Station #2 Input	Station #2 Input	Station #2 Input	Station #2 Input	Station #2 Input	Station #2 Input	Station #2 Input
4	Station #3 Input	Station #3 Input	Station #3 Input	Station #3 Input	Station #3 Input	Station #3 Input	Station #3 Input	Station #3 Input
5	Station #3 Input	Station #3 Input	Station #3 Input	Station #3 Input	Station #3 Input	Station #3 Input	Station #3 Input	Station #3 Input
6	Station #4 Input	Station #4 Input	Station #4 Input	Station #4 Input	Station #4 Input	Station #4 Input	Station #4 Input	Station #4 Input
7	Station #4 Input	Station #4 Input	Station #4 Input	Station #4 Input	Station #4 Input	Station #4 Input	Station #4 Input	Station #4 Input
8	Station #5 Input	Station #5 Input	Station #5 Input	Station #5 Input	Station #5 Input	Station #5 Input	Station #5 Input	Station #5 Input
9	Station #5 Input	Station #5 Input	Station #5 Input	Station #5 Input	Station #5 Input	Station #5 Input	Station #5 Input	Station #5 Input
10	Station #6 Input	Station #6 Input	Station #6 Input	Station #6 Input	Station #6 Input	Station #6 Input	Station #6 Input	Station #6 Input
11	Station #6 Input	Station #6 Input	Station #6 Input	Station #6 Input	Station #6 Input	Station #6 Input	Station #6 Input	Station #6 Input
12	Station #7 Input	Station #7 Input	Station #7 Input	Station #7 Input	Station #7 Input	Station #7 Input	Station #7 Input	Station #7 Input
13	Station #7 Input	Station #7 Input	Station #7 Input	Station #7 Input	Station #7 Input	Station #7 Input	Station #7 Input	Station #7 Input
14	Station #8 Input	Station #8 Input	Station #8 Input	Station #8 Input	Station #8 Input	Station #8 Input	Station #8 Input	Station #8 Input
15	Station #8 Input	Station #8 Input	Station #8 Input	Station #8 Input	Station #8 Input	Station #8 Input	Station #8 Input	Station #8 Input

*Inputs from feedback option when ordered

Diagnostics

LED Functions

Upon power up, the LED's indicate the status of the unit. There are two sets of LED's on the Type-5500: network status and auxiliary power.

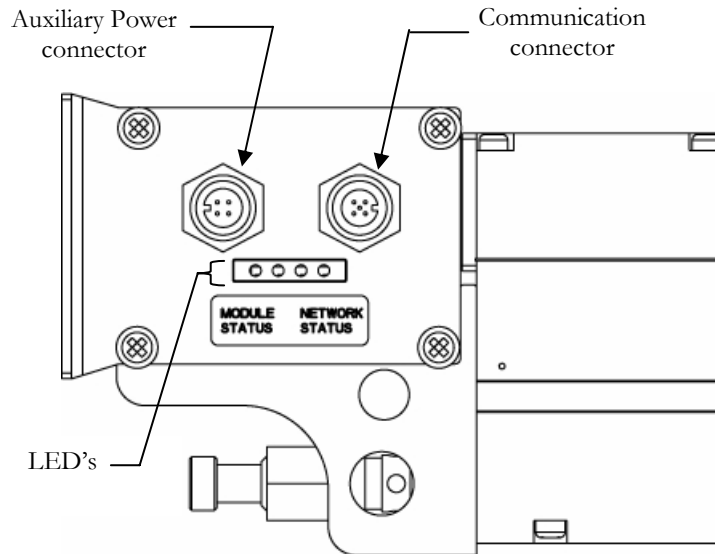

LED Name	Color	Status	Description
Network	Green	OFF	Device is not on-line. Bus power not applied; Physical problem with network; Improper baud rate.
		ON	Normal operation. Device is on-line and has established a connection.
		FLASHING	Device is on-line but has no established connections.
	Red	ON	The device has detected a bus error that has rendered it incapable of communicating on the network; Duplicate MAC ID; "Bus Off" condition; Physical problem with network.
FLASHING		Communication failure – one or more I/O connections have timed out.	
Aux Power	Green	ON	DC Power applied to pin 1 on Aux. Power Connector.
		OFF	No DC Power present to pin 1 on Aux. Power connector.

Appendix

System Specifications

Electrical	
Supply Voltage	Valves: 24 VDC +/- 10% Bus: 11 to 25 VDC
Bus (Network) Power Current Draw	25ma Max. @ 24 VDC
Current	Total current on the Aux. Power Connector (“Regulators” - Pin#1 and “Node” - Pin4) must not exceed 4 amperes.
Recommended External Fuse	External fuses should be chosen depending upon manifold configuration. Please refer to power consumption chart on page 12 for additional fuse sizing information.
Operating Temperature for Electronic Components	23 to 114° F (-5 to 46 °C)

Factory Default Settings

Description	Default
Node Address	63
Baud Rate	Autobaud enabled
I/O Message Type	Polled

Troubleshooting Troubleshooting

<i>Symptom</i>	<i>Possible Cause</i>	<i>Solution</i>
“Scanner Error 78”	Node address is mapped in the scanner, but not seen by the scanner on the network.	Verify that the node address and baud rate are set correctly and that Aux. power is applied.
“Scanner Error 77”	Rx/Tx values of node do not match the valves set in the scan list.	Adjust Rx/Tx values in the DeviceNet software to match the physical configuration of the manifold. Refer to page 24 for further details.
“Scanner Error 73” <i>Device ID information doesn't match electronic key in scan list table entry</i>	In RSNetWorx for DeviceNet major and minor rev. boxes are checked in the Electronic Key of the scan list.	For simplicity when using the ADR function leave the major and minor rev. boxes unchecked in the scan list's electronic key
Will not go on-line. Network Status LED is Red. Module Status LED is Green.	Duplicate MAC ID	Change Mac ID (address) of the node and cycle power
Network Status LED off	CAN_HI / CAN_LO Reversed	Reverse wiring for proper connection
Module LED Flashing	Power not properly applied	Power must be present between V+ and pin V- on the communication connector for the node to function properly. See page 10 for Details
Module LED off	Power not properly applied	24VDC must be present between the +24 VDC (Node and Inputs) pin and the Common pin of the MINI auxiliary power connector even if Discrete I/O modules are not installed See page 10 for Details
Node cannot communicate (Go On-line). Network status LED is off. Module status LED is blinking.	Network power is missing or outside acceptable range.	Check network power for proper value of 11-25 VDC.

Troubleshooting Continued – Error 77

When using an Allen Bradley controller, a frequent error that can occur is “Error 77”. “Error 77” is an I/O Mismatch error, meaning that the DeviceNet scanner and ControlAir DeviceNet manifold have different Input and Output Sizes. These pages will describe how to resolve this issue.

1. First, find the Rx and Tx sizes of the manifold. In RsNetworx for DeviceNet, see I/O Sizing Table on page 16.
2. Double click on the DeviceNet scanner and go to the “Scanlist” tab.
3. Left click on the node that needs to be configured, and left click on the “Edit I/O Parameters” button.

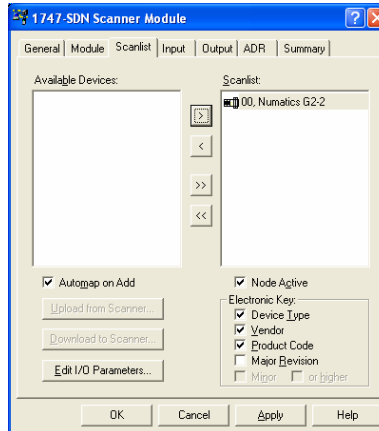

4. Change the “Input Size” and “Output Size” to the numbers you found in Step 1. This will fix the “Error 77” error code.

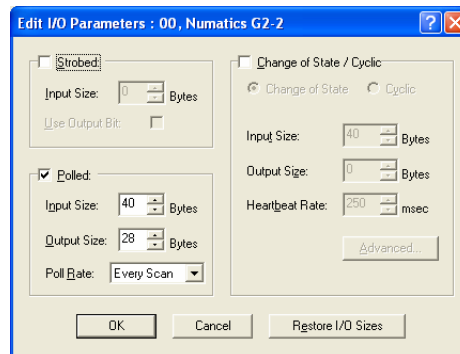

5. Left click on the “OK” button in the “Edit I/O Parameters” window. Left click “Apply” and then “OK” in the Scanner module window and download the newly revised parameters.

Glossary of Terms

The following is a list and description of common terms and symbols used throughout this document:

ADR	Auto-Device Replacement is a feature (enabled by Allen Bradley scanners) that consists of Configuration Recovery and Auto-Address Recovery. Configuration Recovery (CF) refers to the scanner's ability to store a device's configuration. Auto-Address Recovery (AAR) refers to the ability of the scanner to change a device's node address from 63 to that desired by the scanner. Please refer to Allen Bradley's Release Notes # 1747-5.8-RN1 for additional information.
Auto-Baud	A technology that enables the communication node to automatically set its own baud rate to match the DeviceNet scanners' baud rate
Bit	Smallest unit of digital information either a "0" or "1"
Bit mapping	Chart showing which bit is connected to which physical input or output point
Byte	8 bits (1/2 word)
CAN_H	Controller Area Network – High; Communication Line
CAN_L	Controller Area Network – Low; Communication Line
CANBUS	Serial communication BUS network based on CAN protocol
Change of State	I/O message type in which either the expiration of the transmission timer or a change in input state triggers data production.
Comm. Fault	One or more of the I/O connections have timed out.
Cyclic	I/O message type in which data production is triggered by the expiration of the transmission timer.
DeviceNet Manager	Allen-Bradley's DeviceNet configuration software
Discrete I / O	The Inputs / Outputs that are available via the "Discrete I/O" side of manifold
EDS file	<u>E</u> lectronic <u>D</u> ata <u>S</u> heet. A text file, which contains specific product information, definitions of product capabilities and configurable parameters necessary for operation on a DeviceNet network.
EDS Stub file	An abridged version of the EDS file, which contains only the minimum information necessary to make the product functional on a DeviceNet network.
Ground	This term is used to indicate an earth ground
Group 2	DeviceNet message group applicable to Numatics' Serial/Bus products
I/O	Any combination of Inputs and Outputs
MAC ID	Media Access Connection Identification (00-63) – Node (network drop) address
NEMA	National Electrical Manufacturers Association
ODVA	Open DeviceNet Vendor Association
Polled	I/O message type in which the device consumes I/O data from its master and produces I/O data when the master requests it.
RS Network	Allen-Bradley's DeviceNet configuration software
Rx/Tx	Rx = Consumed byte size; analogous to Input byte size. Tx = Produced byte size; analogous to Output byte size.
Word	2 Bytes (16 bits)

Technical Support

For technical support, contact your local ControlAir distributor. Additional assistance is available from ControlAir Inc. at (603) 889-1844 and ask for Technical Support.

Issues relating to network set-up, PLC programming, sequencing, software related functions, etc... should be handled with the appropriate product vendor.

Information on EDS files, local distributors, and other ControlAir, Inc. products and support issues can be found on the ControlAir, Inc. WEB site at: <http://www.controlair.com>