

Type 550X

Miniature I/P, E/P Transducer

Installation, Operation and Maintenance Instructions

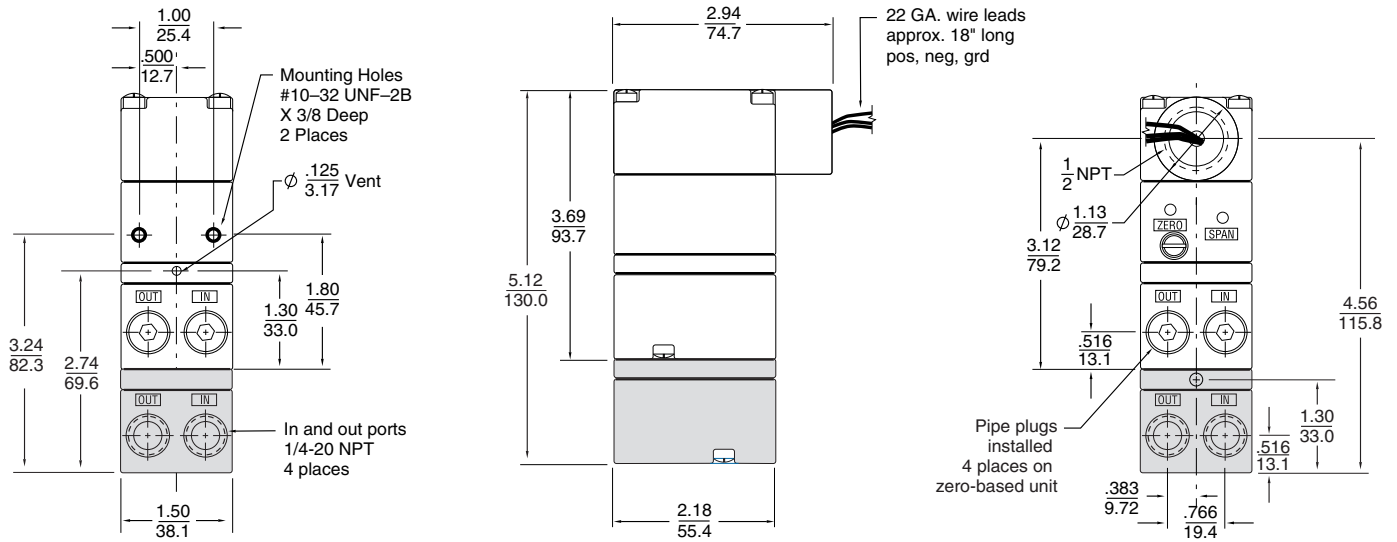

Shaded areas and associated dimensions apply to the zero based unit only.

Contents

Section	Description	Page
1.0	Installation & Approvals	3
2.0	Operation	7
3.0	Maintenance & Repairs	7
4.0	Troubleshooting	8
5.0	Warranty	8



8 Columbia Drive
 Amherst, NH 03031 USA
 603-886-9400
 Fax: 603-889-1844
 www.controlair.com
 sales@controlair.com



DANGER, WARNING, CAUTION and NOTE statements

DANGER Refers to conditions or hazards which could result in serious personal injury or death.

WARNING Refers to conditions or hazards which could result in personal injury.

CAUTION Refers to conditions or hazards which could result in equipment or property damage.

NOTE Alerts you to facts or special instructions.

ALL DANGER, WARNING, AND CAUTION NOTICES MUST BE COMPLIED WITH IN FULL.

SPECIFICATIONS

Functional Specifications

	STANDARD RANGE			ZERO-BASED RANGE		
Inputs	4-20 mA	0-5 VDC 1-5 VDC	0-10 VDC 1-9 VDC	4-20 mA	0-5 VDC 1-5 VDC	0-10 VDC 1-9 VDC
Outputs	3-15 psig 3-27 psig 6-30 psig 2-60 psig 3-120 psig	0.20-1.0 BAR 0.20-1.8 BAR 0.40-2.0 BAR 0.14-4.0 BAR 0.20-8.0 BAR		0-30 psig 0-60 psig 0-120 psig	0.00-2.0 BAR 0.00-4.0 BAR 0.00-8.0 BAR	
Air Consumption	1.8 scfh (0.05 m3/hr) at mid range typical			6.0 scfh at mid range typical		
Supply Pressure Note: Supply pressure must be a minimum of 5 psig (0.3 BAR) above maximum output	100 psig (6.9 BAR) max. (3-15, 3-27, 6-30 psig) 150 psig (10.0 BAR) max. (2-60, 3-120 psig)			100 psig (6.9 BAR) max. (0-30, 0-60 psig) 150 psig (10.0 BAR) max. (0-120 psig)		
Flow Capacity	4.5 scfm (7.7 m3/hr) at 25 psig (1.70 BAR) supply (3-15, 3-27, 6-30 psig) 12.0 scfm (20.0 m3/hr) at 100 psig (6.9 BAR) supply (3-15, 3-27, 6-30, 2-60 psig) 20.0 scfm (34.0 m3/hr) at 150 psig (10.0 BAR) supply (3-120 psig)			12.0 scfm (20.0 m3/hr) at 100 psig (6.9 BAR) supply (0-30, 0-60 psig) 20.0 scfm (34.0 m3/hr) at 150 psig (10.0 BAR) supply (0-120 psig)		
Temperature Limits	-20° to +150° F (-30° to +65° C)			-20° to +150° F (-30° to +65° C)		
Impedance	4-20 mA	3-15 psig 3-27 psig 6-30 psig 2-60 psig 3-120 psig	180 Ohms 240 Ohms 240 Ohms 245 Ohms 280 Ohms	4-20 mA	0-30 psig 0-60 psig 0-120 psig	290 Ohms 300 Ohms 315 Ohms
	0-5 VDC	3-15 psig 3-27 psig 6-30 psig 2-60 psig 3-120 psig	615 Ohms 550 Ohms 550 Ohms 520 Ohms 500 Ohms	0-5 VDC	0-30 psig 0-60 psig 0-120 psig	450 Ohms 480 Ohms 495 Ohms
	0-10 VDC	3-15 psig 3-27 psig 6-30 psig 2-60 psig 3-120 psig	1230 Ohms 1100 Ohms 1100 Ohms 1040 Ohms 1000 Ohms	0-10 VDC	0-30 psig 0-60 psig 0-120 psig	900 Ohms 960 Ohms 990 Ohms
	1-5 VDC	3-15 psig 3-27 psig 6-30 psig 2-60 psig 3-120 psig	495 Ohms 440 Ohms 440 Ohms 495 Ohms 475 Ohms	1-5 VDC	0-30 psig 0-60 psig 0-120 psig	410 Ohms 460 Ohms 455 Ohms
	1-9 VDC	3-15 psig 3-27 psig 6-30 psig 2-60 psig 3-120 psig	985 Ohms 880 Ohms 880 Ohms 900 Ohms 880 Ohms	1-9 VDC	0-30 psig 0-60 psig 0-120 psig	830 Ohms 800 Ohms 785 Ohms

Performance Specifications

	STANDARD RANGE	ZERO-BASED RANGE
Linearity (Independent)	<±0.5% of span	<±1.5% of span
Hysteresis, and Repeatability	<0.5% of span	<1.0% of span
Supply Pressure Sensitivity	<0.1% of span per 1.0 psig (0.07 BAR)	<0.02% of span per 1.0 psig (0.07 BAR)

Physical Specifications

Port Sizes	Pneumatic	1/4" NPT
Media	Clean, dry, oil-free, instrument air, filtered to 40 micron	
Electrical Connections	Conduit 1/2" NPT, Terminal Block, DIN 43650	
Mounting	Direct wall, panel, 1 1/2" pipe, DIN rail or Manifold	
Materials	Housing	Chromate-treated aluminum with epoxy paint. NEMA 4X (IP65)
	Elastomers	Buna-N
	Trim	Stainless steel; brass; zinc-plated steel
Weight	Standard Unit: 1.3 lbs	Zero-based Unit: 1.7 lbs

1. INSTALLATION AND APPROVALS

1.1 Pre-installation Requirements

1.1.1 Environment: Suitable for installation in the following locations:

- Intrinsically safe operation in hazardous locations outdoors (NEMA 4X, CSA.ENC.4 & IP65)
- See section 1.5, 1.6 and 1.7 for Factory Mutual (FM), Canadian Standards (CSA) and ATEX approvals.

DANGER *All wiring must be made to all local and national codes appropriate to the area of installation.*

1.1.2 Electrical Input: 4-20 mA_{dc} current source or 0-5, 0-10, 1-5, 1-9 VDC voltage source depending on model.

1.1.3 Air supply: Clean, dry, oil free instrument air filtered to 40 micron

NOTE *Clean all pipe lines to remove dirt and scale prior to installation. Failures attributable to instrument air supply contamination are not covered by the warranty.*

CAUTION *This instrument vents to atmosphere. The use of supply gas other than air can create a hazardous environment.*

1.2 Mounting

- 1.2.1 The Type 550X has a standard mounting kit that enables 1½” pipe, panel or wall mounting of the unit.
- 1.2.2 To mount unit to a 1½” pipe, use two 10-32 holes on the back of the unit to attach bracket to transducer. Then place U-bolt around pipe and through bracket. Place nuts on U-bolt and tighten (see figure 1).
- 1.2.3 With access to the rear of a panel, attach transducer using two 10-32 screws and the two threaded mounting screws on the back of the unit. With no access to the back of the panel, attach the bracket to the transducer using the two 10-32 holes on the back of unit and mount bracket to panel using four 10-32 screws (see figure 2).
- 1.2.4 Due to it's light weight, the Type 550X can also be mounted in line with support provided by the supply and output piping.
- 1.2.5 Because of it's small size, the Type 550X can easily be mounted to a manifold. ControlAir's Type 925 multifunction supply manifold is designed for this purpose.

Figure 1 - Pipe Mounting Figure 2 - Panel Mounting

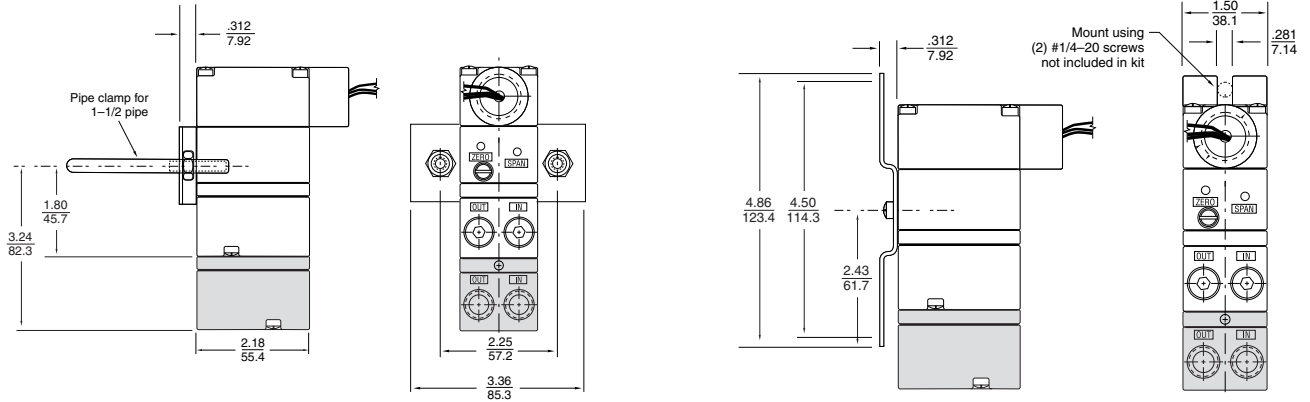

Shaded areas and associated dimensions apply to the zero based unit only.

- 1.2.6 The Type 550X can be mounted to DIN-rail using the optional kit that is ControlAir part number 445-766-024. This will allow the transducer to mount to DIN 50045, 50035, 50022 rails (See figure 3).

Figure 3 - DIN Rail mounting kit 445-766-024

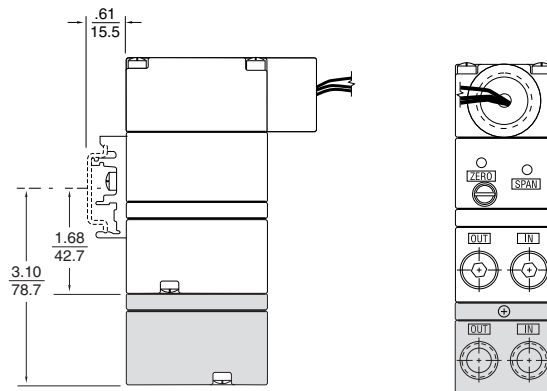

Shaded areas and associated dimensions apply to the zero based unit only.

1.3 Pneumatic Connections

- 1.3.1 Clean all pipe lines to remove dirt and scale prior to installation.
- 1.3.2 Supply air must be filtered to 40 microns and free of moisture and lubricants.
- 1.3.3 Two (2) 1/4” NPT ports are provided for supply air connections. Either port may be used. The unused port must be plugged with the pipe plug included with the unit.
- 1.3.4 Two (2) 1/4” NPT ports are provided for pneumatic output connections. Either port may be used and one may be used for the mounting of an output gauge. If no gauge is installed, the unused port must be plugged with the pipe plug included with the unit.

1.4 Electrical Connections

- 1.4.1 Both the I/P and E/P versions of the Type 550X are two wire devices (do not require a separate power source), plus a safety ground. The I/P unit requires a variable input current of 4-20 mA. The E/P version requires a DC voltage input signal such as 0-10 VDC.
- 1.4.2 1/2" NPT conduit connection (A) is made using 18" pigtail wire coming from unit. For I/P (current to pressure) versions, electrical connections are made to the red (+) and black (-) leads. The green lead is furnished for case ground. For E/P (voltage to pressure) versions, electrical connections are made to the red (+) and black (-). The green lead is furnished for case ground (see figure 4).

Figure 4 - 1/2" Conduit Connection

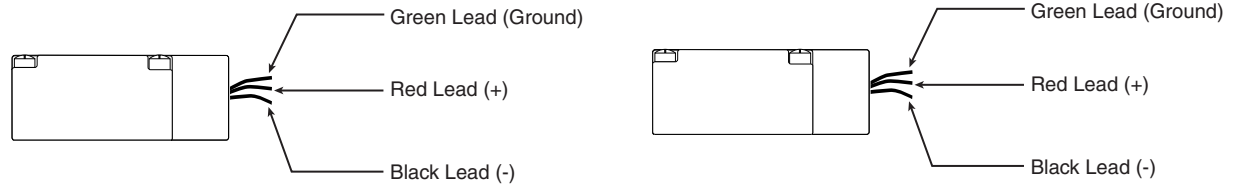

I/P Conduit Connection

E/P Conduit Connection

- 1.4.3 **DIN 43650 Connector (D)** electrical connections are made as shown in figure 5.

Figure 5 - DIN 43650 Connections

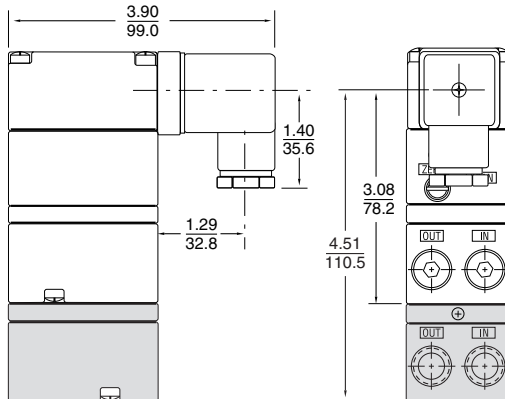

Terminal	I/P Connection	E/P Connection
1	Positive (+)	Positive (+)
2	Negative (-)	Negative (-)
3	Not Used	Not Used
⊥	Ground (⊥)	Ground (⊥)

Shaded areas and associated dimensions apply to the zero based unit only.

- 1.4.4 **Terminal Block (T)** Electrical connections are made to the positive (+) and negative (-) terminals. For direct acting operation connect the positive side of the input signal to the (+) terminal.
- 1.4.5 The use of shielded cable is recommended.

Figure 6 - Terminal Block Connections

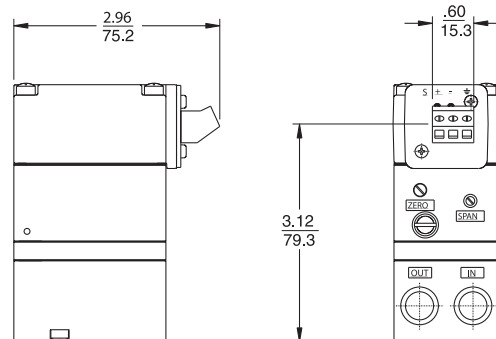

Terminal	I/P-E/P Connection
+	Positive (+)
-	Negative (-)
S	Not Used
⊥	Ground (⊥)

1.5 Factory Mutual Research Corporation (FM) & Canadian Standards (CSA) Approvals



Intrinsically Safe (1/2" NPT Conduit)

Class I, II, III, Division 1,
Groups C, D, E, F, & G
Enclosure Nema 4X(IP 65)
Temp. Code T4 Ta = 70° C
Rated 4-20 mA, 30 VDC Max.

Intrinsically Safe (DIN & Terminal)

Class I, Division 1, Groups C & D
Temp. Code T4 Ta = 70° C
Rated 4-20 mA, 30 VDC Max.

Non-Incendive (Conduit, DIN, Terminal)

Class I, Division 2,
Groups A, B, C & D
Temp. Code T4 Ta = 70° C

Suitable for (Conduit only)

Class II & III, Division 2,
Groups F & G
Temp. Code T4 Ta = 70° C

Entity Parameters

Ui (Vmax) = 30 VDC Ci = 0 uF
Ii (Imax) = 125 mA Li = 0 m H
Pi = .7 w Max.

1.6 ATEX Approvals (option k)

EEx ia IIB T4
Tamb = -30° C to +70° C
Nemko 03ATEX1574X

Entity Parameters

Ui (Vmax) = 30 VDC Ci = 0 uF
Ii (Imax) = 125 mA Li = 0 m H
Pi = .7 W Max.



INSTALLATION DRAWING NO. 431-990-036

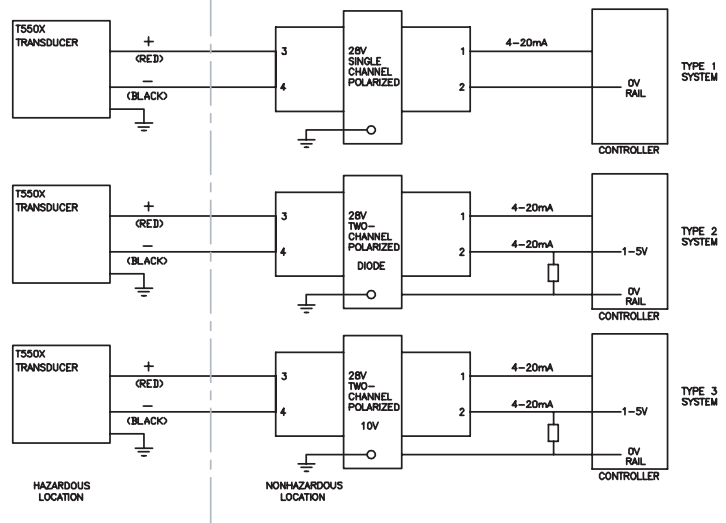
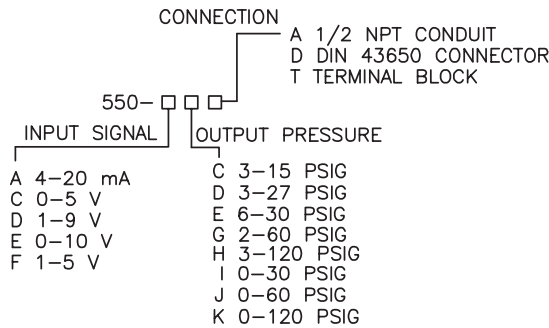

Notes

- Control equipment connected to the Associated Apparatus must not use or generate more than 250 Vrms or Vdc.
- The IS Barriers or Equipment (Associated Apparatus) must be FM Approvals and CSA certified and the configuration of associated Apparatus must be FM Approvals and CSA certified under the Entity Concept. The Associated Apparatus may be installed within the Hazardous (Classified) location for which it is certified. The Associated Apparatus and hazardous location loop apparatus manufacturer's control drawings must be followed when installing this equipment. An AEx [ib] Associated Apparatus is suitable only for connection to Class I, Zone1, Hazardous (Classified) Locations and is not suitable for Class I, Zone 0, or Class I, Division 1 Hazardous (Classified) Locations.
- Installation should be in accordance with ANSI/ISA RP12.06.01, "Installation of Intrinsically Safe Systems for Hazardous (Classified) Locations" and Article 500 of the National Electrical Code (ANSI/NFPA 70) and Section 18 of the Canadian Electrical Code.
- The connection option "A" is suitable for Type 4X installations. All others must be mounted in a suitable enclosure.

- The connection option "A" is suitable for Class I, II, and III, Division 2, Groups A, B, C, D, F, and G hazardous (classified) locations. Dust-tight conduit seal must be used when installed in Class II and Class III environments. The connection options "D" and "T" are suitable for Class I, Division 2, Groups A, B, C, and D hazardous (classified) locations. Transducers to be installed in accordance with the National Electrical Code (ANSI/NFPA 70) Division 2 hazardous (classified) location wiring techniques and the Canadian Electrical Code.
- The Intrinsic Safety Entity concept allows the interconnection of two FM Approvals or CSA Certified Intrinsically safe devices with entity parameters not specifically examined in combination as a system when:
 - Ui or Vmax > Uo or Voc
 - Ii or Imax > Io or Isc or It
 - Ca or Co > Ci + Ccable
 - La or Lo > Li + Lcable
 - Pi > Po.
- No revision to this drawing is permitted without prior FM Approval/CSA Certification.

1.7 EC Declaration of Conformity



We, ControlAir, Inc.
8 Columbia Drive
Amherst, NH 03031

Declare that the Type 550X Transducer family to which this declaration applies, comply with these standards:
EN 50082-1:1998
EN 55011:1999
EN 61010-1:1993 including AMD2:1995

Following the provisions of EMC directive 89/336/EEC

2. OPERATION

2.1 Calibration

- 2.1.1 All units are shipped from the factory calibrated, direct acting.

NOTE *Factory calibration is susceptible to shift due to handling during transit. ControlAir recommends that all units be recalibrated prior to use.*

- 2.1.2 Though the units are shipped fully calibrated it is suggested that the user check the calibration to ensure that settings and operation match the application requirements.

NOTE *The unit must be calibrated in the plane it is mounted in.*

NOTE *Repeated cycling of supply pressure may cause increased leakage and premature product failure.*

2.2 Direct Acting Calibration

- 2.2.1 In direct acting operation the unit is calibrated so that minimum input signal corresponds to minimum output pressure and increasing input signal results in increasing output pressure.

- 2.2.2 Apply the minimum input signal of the range being used (e.g. 4 mA for a 4-20 mA unit).

- 2.2.3 Observe the output pressure. If necessary, adjust the zero screw until reaching minimum output pressure setting. Turn zero screw clockwise to increase and counter clockwise to decrease.

NOTE *If unable to achieve output during the calibration process, follow the steps outlined in 3.1.4 to clean the orifice. Then turn the zero adjustment screw clockwise slowly and carefully until output pressure begins to respond.*

Caution *Turning the zero screw too fast or too far can cause permanent damage.*

- 2.2.4 Apply the maximum input signal of the range being used (e.g. 20 mA for a 4-20 mA unit).

- 2.2.5 Observe the output pressure. If necessary, adjust the span screw until reaching maximum output pressure setting.

NOTE *For I/P (current) input models, turn span screw clockwise to increase pressure, counter clockwise to decrease pressure. For E/P (voltage) input models, turn span screw clockwise to decrease pressure, counter clockwise to increase pressure.*

- 2.2.6 After setting the span it will be necessary to recheck the zero. Repeat steps 1-4 until both end points are at required values.

2.3 Reverse Acting Calibration

- 2.3.1 For reverse acting calibration, consult the factory.

3. MAINTENANCE AND REPAIRS

NOTE *Under normal circumstances, no maintenance should be required.*

3.1 Instrument Air Filtration

- 3.1.1 Failures due to instrument supply air contamination are not covered by warranty.

- 3.1.2 Use of oil and/or water saturated instrument air can cause erratic operation.

- 3.1.3 Poor quality instrument air can result in unit failure. It is recommended that a filter regulator (such as ControlAir Type 300) be placed upstream of each unit where oil and/or water laden instrument air is suspected.

- 3.1.4 If clean, dry air is not used the orifice can become blocked. To clean, first turn off supply air, then remove the screw located on the side of the unit above the "out" port. The orifice is a very small hole on the side of the screw. Unplug the orifice using a wire that has a smaller diameter than 0.012" (0.30mm). Replace screw tightly into unit.

3.2 Factory Repairs

- 3.2.1 In the event of unit failure, the Type 550X can be returned to the factory through point of purchase for warranty repair if the warranty period has not expired.
- 3.2.2 All units returned for repair must be authorized prior to receipt at the factory. Contact a representative at the point of purchase to receive a Return Authorization Number.

3.3 Field Repairs

- 3.3.1 Service kits for elastomer components in the Type 550X are available. Consult factory for kit numbers and availability.
- 3.3.2 Replacement components for the Type 550X are available. Consult factory for part numbers and availability.

4. TROUBLESHOOTING

PROBLEM	LOOK FOR	SOLUTION
No or low output	Zero adjustment Supply pressure too low	Reset zero (2.2.3) Increase supply pressure (see specs)
Unstable/low output	Electrical connection Clogged orifice	Check connection/signal (1.1.2) Clean orifice (3.1.4)
Erratic operation	Liquid/contamination in air supply	Clean air supply (1.1.3)
Works in reverse	Pressure goes down when signal is increased	Reverse input wires (1.4.2)
Output equals supply pressure	Improper pneumatic connections	Insure that supply is connected to "IN" port and output is connected to "OUT" port (1.3.3, 1.3.4)

NOTE *If problems are not solved by troubleshooting procedures, contact a factory applications engineer at 603-886-9400 for further assistance.*

5. WARRANTY & DISCLAIMER

ControlAir, Inc. products are warranted to be free from defects in materials and workmanship for a period of eighteen months from the date of sale, provided said products are used according to ControlAir, Inc. recommended usages. ControlAir, Inc.'s liability is limited to the repair, purchase price refund, or replacement in kind, at ControlAir, Inc.'s sole option, of any products proved defective. ControlAir, Inc. reserves the right to discontinue manufacture of any products or change products materials, designs or specifications without notice. Note: ControlAir does not assume responsibility for the selection, use, or maintenance of any product. Responsibility for the proper selection, use, and maintenance of any ControlAir product remains solely with the purchaser and end user.

WARNING *These products are intended for use in industrial compressed-air systems only. Do not use these products where pressures and temperatures can exceed those listed under Specifications.*

Before using these products with fluids other than air, for non-industrial application, life-support systems, or other applications not within published specifications, consult ControlAir, Inc.



8 Columbia Drive
Amherst, NH 03031 USA
603-886-9400
Fax: 603-889-1844
www.controlair.com
sales@controlair.com

